



User Manual

QEC-RXXDT0/D0T Series

EtherCAT Digital I/O Module
With 32-ch Digital Input/Output

(Revision 2.1)

REVISION

Date	Version	Description
2023/11/30	Version1.0	New Release.
2024/01/11	Version2.0	Update Specification.
2026/04/01	Version2.1	Add wiring information.

COPYRIGHT

The information in this manual is subject to change without notice for continuous improvement in the product. All rights are reserved. The manufacturer assumes no responsibility for any inaccuracies that may be contained in this document and makes no commitment to update or to keep current the information contained in this manual.

No part of this manual may be reproduced, copied, translated or transmitted, in whole or in part, in any form or by any means without the prior written permission of ICOP Technology Inc.

©Copyright 2026 ICOP Technology Inc.

Ver.2.1 April, 2026

TRADEMARKS ACKNOWLEDGMENT

ICOP® is the registered trademark of ICOP Corporation. Other brand names or product names appearing in this document are the properties and registered trademarks of their respective owners. All names mentioned herewith are served for identification purpose only.

For more detailed information or if you are interested in other ICOP products, please visit our official websites at:

- Global: www.icop.com.tw
- USA: www.icoptech.com
- Japan: www.icop.co.jp
- Europe: www.icoptech.eu
- China: www.icop.com.cn

For technical support or drivers download, please visit our websites at:

- https://www.icop.com.tw/resource_entrance

For EtherCAT solution service, support or tutorials, 86Duino Coding IDE 500+ introduction, functions, languages, libraries, etc. Please visit the QEC website:

- QEC: <https://www.qec.tw/>

This Manual is for the QEC series.

SAFETY INFORMATION

Read all safety instructions carefully before installation or operation.

General

- Handle the unit with care. Always use both hands when carrying or positioning the module.
- Keep the module dry and away from water, moisture, and condensation to prevent electric shock or fire hazards.
- Never touch un-insulated terminals or wiring while the power supply is connected.
- If the module will not be used for an extended period, disconnect it from the power source to prevent transient overvoltage damage.

Power

- Supply voltage must be within +19 to +50 VDC (Typ. +24 VDC) before connecting to the module.
- Verify the power source voltage is within the specified range before powering on.
- Operating temperature range: -20 to +70 °C (standard); -40 to +85 °C (optional).

I/O Wiring

- Always follow the wiring diagrams in this manual exactly. Incorrect wiring may permanently damage the module or connected equipment.
- **Shared GND (Common Ground) Design:** Each group of 4 I/O channels shares one common ground (COM) pin. All 4 channels in a group **must** share the same COM. Mixing COM connections across groups, or connecting loads with different ground references to the same group, will cause incorrect operation or permanent damage.
- For Digital Input: ensure the signal source voltage is within 24–40 VDC. Do not exceed the rated load voltage.
- For Digital Output: each channel supports a maximum load current of 250 mA. Exceeding this limit will damage the MOSFET output stage.

WARNING!



DO NOT ATTEMPT TO OPEN OR DISASSEMBLE THE ENCLOSURE OF THIS PRODUCT. SERVICING MUST BE PERFORMED BY A QUALIFIED TECHNICIAN. CONTACT YOUR AUTHORIZED DEALER FOR REPAIR OR MAINTENANCE.

CONTENT

Ch. 1 General Information	1
1.1 Introduction	2
1.2 Specifications	3
1.3 Dimension	4
1.4 Mounting Instruction.....	5
1.5 Ordering Information	6
1.5.1 Reference Ordering Part Number:	6
Ch. 2 Hardware System	7
2.1 General Technical Data.....	8
2.2 Connector Summary	9
2.2.1 EtherCAT Interface	10
2.2.1.1 EC IN	10
2.2.1.2 EC OUT.....	10
2.2.2 Power Connector	12
2.2.3 Power and Connection Status LEDs	13
2.2.3.1 Power Status LED	13
2.2.4 I/O Status LEDs	15
2.2.4.1 LED Color Comparison	15
2.2.5 I/O Connector.....	16
2.2.5.1 Digital Input (QEC-RXXDT0H/ QEC-RXXDT0L)	16
2.2.5.2 Digital Output (QEC-RXXD0TH/ QEC-RXXD0TL)	17
2.2.6 DIN-Rail installation	18
2.3 Wiring to the Connector.....	19
2.3.1 Connecting the wire to the connector.....	19
2.3.2 Removing the wire from the connector.....	19
2.3.3 Application Wiring.....	20
2.3.3.1 Digital Input (QEC-RXXDT0H / QEC-RXXDT0L)	20
2.3.3.2 Digital Output (QEC-RXXD0TH / QEC-RXXD0TL)	22
Ch. 3 Hardware Installation.....	24
3.1 DIN-Rail installation.....	25
3.2 Removing QEC-RXXD Unit	26
Ch. 4 Getting Started.....	27
4.1 Introduction	28
4.2 QEC-M + 86Duino IDE	29
4.2.1 Hardware Preparation and Connection	29
4.2.2 Software/Development Environment.....	30
4.2.3 Connect to your PC and set up the environment	31
4.2.4 Configuration and Operation	32
4.2.4.1 Step 1: Turn on 86EVA and scan.....	32
4.2.4.2 Step 2: Set the parameters	33

4.2.4.3	Step 3: Generation the code	34
4.2.4.4	Step 4: Upload the code	36
4.2.5	EthercatDevice_QECRXXD Class	37
4.2.5.1	Example 1: Digital Read.....	38
4.2.5.2	Example 2: Digital Write	39
4.2.5.3	Example 3: Distributed Clock (DC)	40
4.3	Third-Party EtherCAT MainDevice (e.g., TwinCAT)	41
4.3.1	Install the ESI file	41
4.2.2	Add the QEC-R11D88K to the Project	42
4.2.3	Start to Configure the QEC-R11D88K.....	45
4.2.4	Control the QEC-R11D88K.....	47
4.2.4.1	Configure the Digital Output	47
4.2.4.2	Read the Digital Input	49
Ch. 5	SubDevice Information	50
5.1	ESI (EtherCAT SubDevice Information) file.....	51
5.2	Object Dictionary	51
5.2.1	Standard Objects (0x1000-0x1FFF)	52
Index 1000	Device type.....	52
Index 1001	Error register	52
Index 1008	Device name	52
Index 1009	Hardware version	52
Index 100A	52
Index 1018	Identity.....	53
Index 10F1	Error Settings	53
Index 10F8	Timestamp Object.....	53
Index 1600	Digital Output process data mapping	54
Index 1A00	Digital Input process data mapping	55
Index 1C00	Sync manager type	56
Index 1C12	SyncManager 2 assignment	56
Index 1C13	SyncManager 3 assignment	56
Index 1C32	SM output parameter.....	57
Index 1C33	SM input parameter	57
5.2.2	Manufacturer Objects (0x5000-0x5FFF).....	58
Index 0x5xxn	Manufacturer Objects.....	58
5.2.3	Especial Objects (0x6000-0xFFFF).....	59
Index 0x6nnx	Input Data of the Module (0x6000 - 0x6FFF)	59
Index 0x7nnx	Output Data of the Module (0x7000 - 0x7FFF).....	60
Warranty	61



Ch. 1

General Information

1.1 Introduction

The QEC-RXXDT0 and QEC-RXXD0T are ICOP's standard industrial EtherCAT digital I/O SubDevice modules, each supporting up to 32 channels of digital input or output.

Both models are compliant with the EtherCAT Conformance Test Tool (ETG.9400), ensuring interoperability with any EtherCAT MainDevice for rapid deployment in industrial automation applications.



The QEC-RXXDT0H and QEC-RXXD0TH variants support a minimum EtherCAT cycle time of 125 μ s and Distributed Clock (DC) synchronization, making them suitable for high-precision, time-critical applications. Built with modern silicon components, the modules operate at lower thermal output, extending product lifespan. They also feature automatic internal status monitoring – covering voltage, current, operating temperature, and runtime – enabling effective energy and carbon footprint tracking.

The QEC-RXXDT0L and QEC-RXXD0TL are MCU-free variants that simplify configuration and reduce cost. While they do not support high-frequency I/O response or Mailbox services, they are well-suited for standard digital I/O control applications.

The QEC-RXXDT0 digital input module offers polarity-separated channel pins, input wire-break detection, and up to 2,500 Vrms optical isolation. The QEC-RXXD0T digital output module provides up to 3,750 Vrms optical isolation and supports load voltages up to 40 VDC at 200 mA per channel.

The QEC-RXXDT0H and QEC-RXXD0TH models support firmware updates via FoE (File over EtherCAT) and include dual RJ45 ports for EtherCAT Cable Redundancy. Onboard LEDs provide real-time indication of power status, communication state, and I/O channel status for fast troubleshooting. The modules support star, line, and ring network topologies for flexible, cost-efficient deployment.

The QEC-RXXD measures 107.45 \times 66 \times 34 mm and operates from -20 to $+70^{\circ}\text{C}$ standard, with an optional -40 to $+85^{\circ}\text{C}$ extended range. DIN Rail mounting and European-style push-in terminal blocks enable fast, tool-free field installation.

1.2 Specifications

Model Name	QEC-RXXDT0H	QEC-RXXD0TH	QEC-RXXDT0L	QEC-RXXD0TL
Digital Type	Input	Output	Input	Output
I/O Type	Sink (NPN)	Sink (NPN)	Sink (NPN)	Sink (NPN)
Channel	32	32	32	32
I/O Frequency	8KHz	8KHz	—	—
Propagation delay time	150 ns	50 μ s	150 ns	50 μ s
Mailbox Service	Yes	Yes	No	No
Distributed clocks	Yes	Yes	No	No
Digital Input				
Load Voltage	Max. 40 VDC	—	Max. 40 VDC	—
Digital Output				
MOSFET	—	MOSFET	—	MOSFET
Load Voltage	—	Max. 40 VDC	—	Max. 40 VDC
Load Current	—	250 mA	—	250 mA
General				
Connector	32-channel Push-in Terminal (Euroblock)			
Connector Color	Positive: Red Negative: Black	Positive: Orange Negative: Black	Positive: Red Negative: Black	Positive: Orange Negative: Black
Protocol	EtherCAT (RJ-45 x 2)			
Ethernet Standard	IEEE 802.3			
Transmission Rate	100 Mbps			
Power Connector	4-pin Power Input/Output & 2-pin FGND			
Power Requirement	+19 to +50 VDC Power Input (Typ. +24 VDC @ 100-140 mA)			
Power Consumption	3 W	3 W	2.4 W	2.4 W
LED Indicator	PWR, RUN, LINK, ERROR, DI/O status			
Certifications	CE, FCC, VCCI			
Environment				
Isolation Protection, Optocoupler	2500 Vrms	3750 Vrms	2500 Vrms	3750 Vrms
Operating Temperature	-20 to +70 °C			
Hardware				
Dimension	107.45 x 66 x 34 mm (Without DIN-Rail)			
Weight	245 g	265 g	245 g	265 g
Installation	DIN Rail			
Internal Monitoring	Yes	Yes	No	No

1.3 Dimension

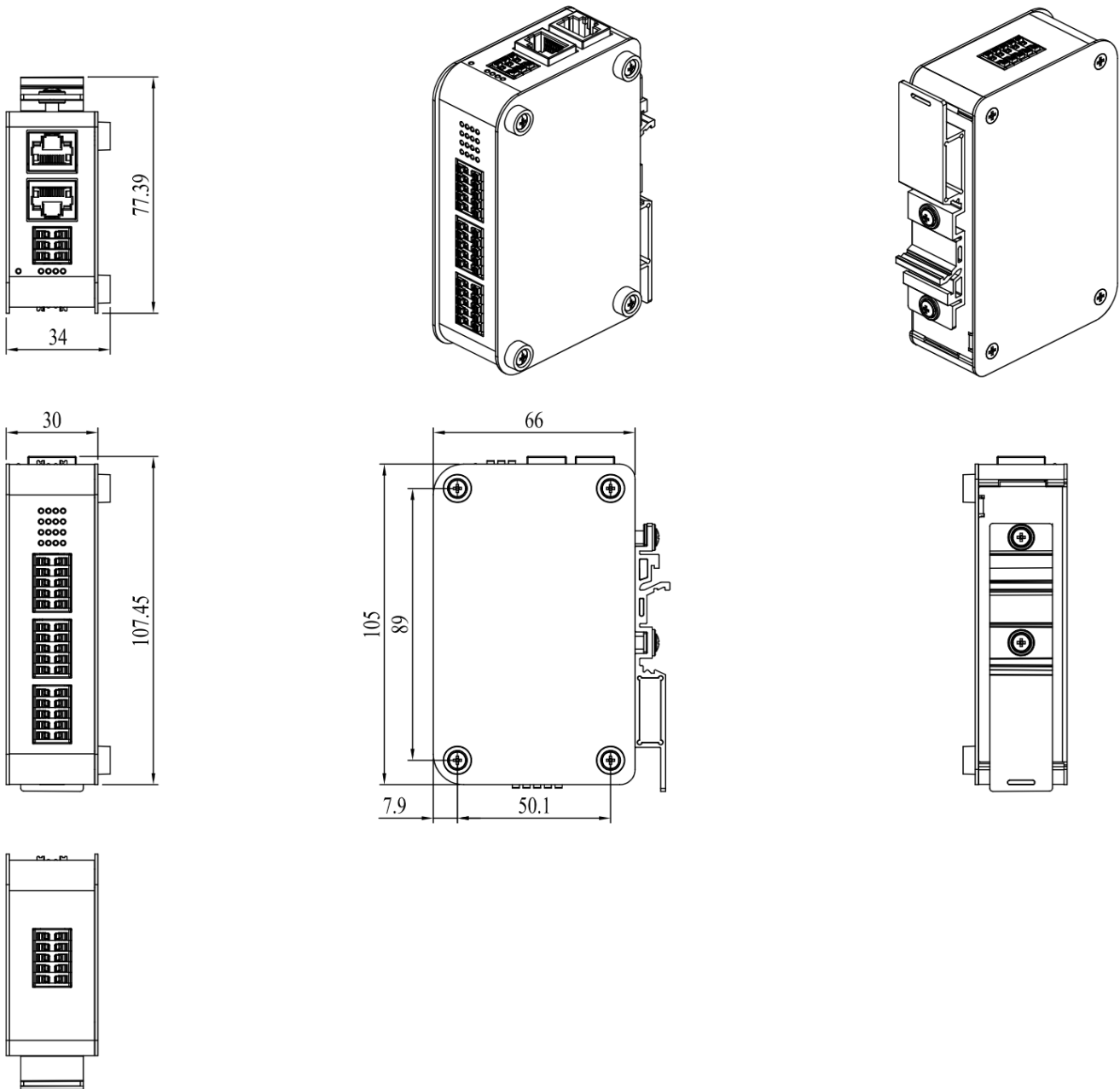

(Unit: mm)

1.4 Mounting Instruction

QEC-RXXDT0 and QEC-RXXD0T are easy-install design to help you set-up your modules easily. Please refer to [Ch.3.1 DIN-Rail installation](#).

- DIN-Rail

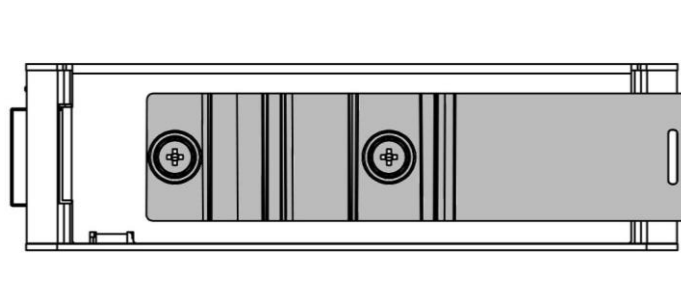
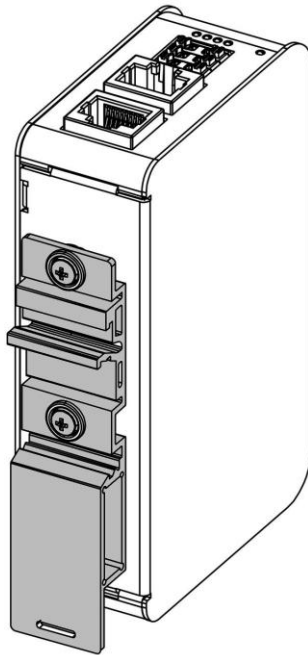

1.5 Ordering Information

Type	RJ45 power source		Functions			Feature	-	Coating
	Input	Output	Digital	Input	Output	Digital Type		
QEC-R	<u>X</u>	<u>X</u>	D	<u>X</u>	<u>X</u>	<u>X</u>		<u>X</u>

1. Type: Code 1~4

R: EtherCAT SubDevice.

2. RJ45 Power source: Code 5~6

Q: RJ45 In/Out w/o power

1: RJ45 PoE Device, Red Plastic Housing

3. Functions: Code 7~9

D: Digital I/O

X: T (32) input channels

X: T (32) output channels

4. Feature: Code 11

H: High-speed Digital Frequency

L: Unsupported Mailbox Service)

5. Coating: Code 13

C: Yes / N: Normal

Q E C - R X X D X X X - X

1.5.1 Reference Ordering Part Number:

Above is the standard Part Number, please contact our sales if you need to order other part number.

- **QEC-R00DT0H-N**: EtherCAT High-speed Digital Input 32 channels modules.
- **QEC-R11DT0L-N**: EtherCAT Digital Input 32 channels modules/PoE.
- **QEC-R00D0TH-N**: EtherCAT High-speed Digital Output 32 channels modules.
- **QEC-R11D0TL-C**: EtherCAT Digital Output 32 channels modules (board with coating).



Ch. 2

Hardware System

2.1 General Technical Data

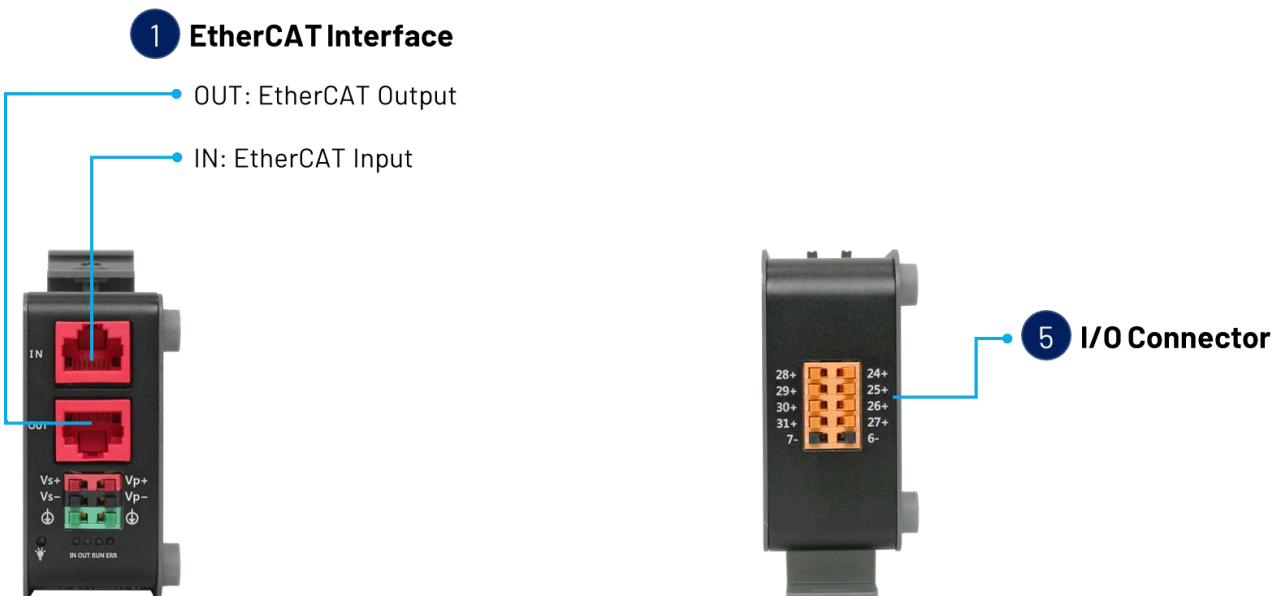
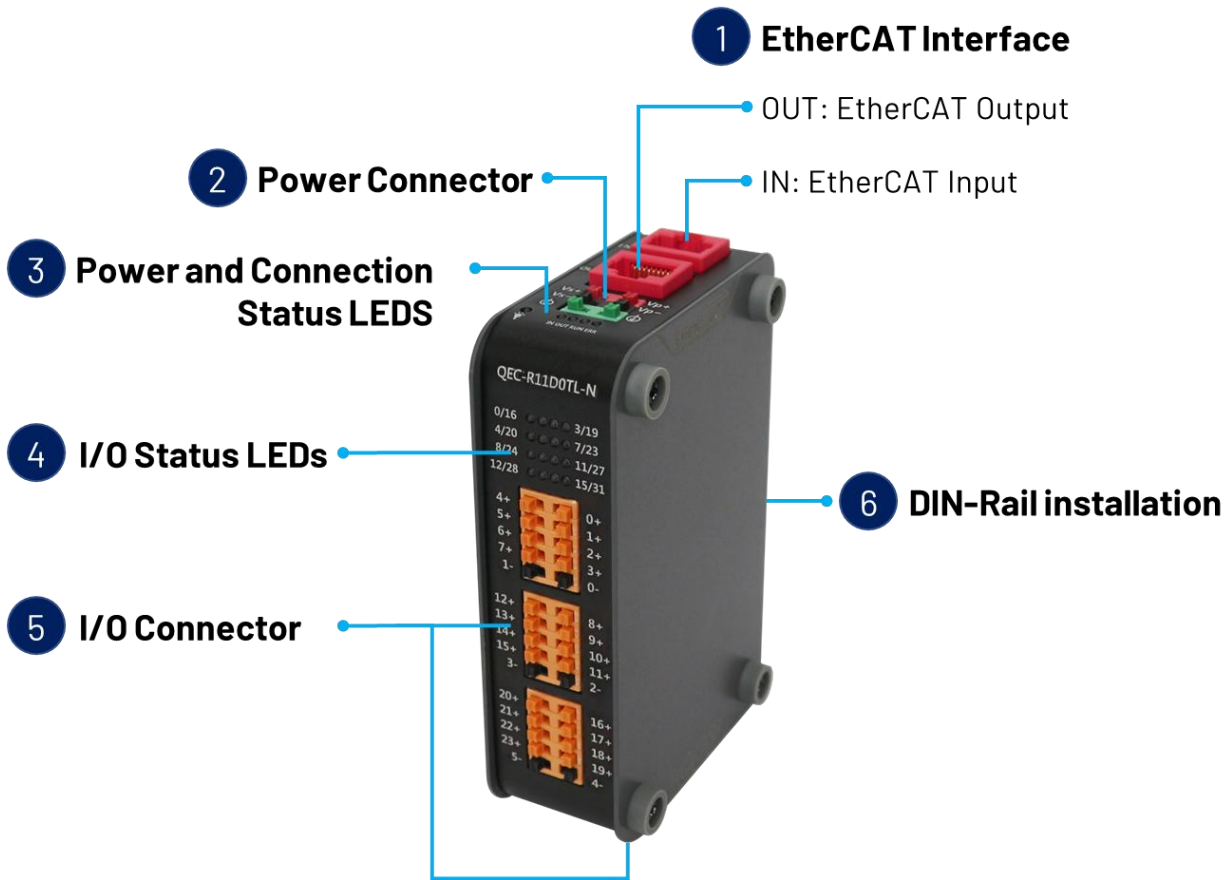

2.2 Connector Summary

No.	Description	Type Narrative	Pin #
1	EtherCAT Interface	OUT	8-pin
		IN	8-pin
2	Power Connector	Terminal Block Interface	6-pin
3	Power and Connection Status LEDs	External Status LEDs	-
4	I/O Status LEDs	External Status LEDs	-
5	I/O Connector	32-ch Push-in Terminal (Euroblock)	40-pin
6	DIN-Rail	-	-

2.2.1 EtherCAT Interface

RJ45 Connectors.

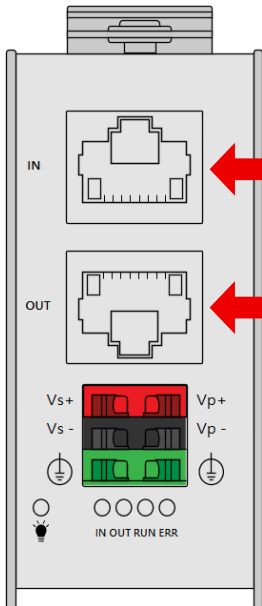

2.2.1.1 EC IN

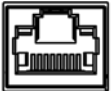
	Pin #	Signal Name	Pin #	Signal Name
 8 2,1	1	LAN1_TX+	2	LAN1_TX-
	3	LAN1_RX+	4	VS+
	5	VP+	6	LAN1_RX-
	7	VS- (GND)	8	VP- (GND)

* PoE LAN with the Red Housing; Regular LAN with Black Housing.

* L4, L5, L7, L8 pins are option, for RJ45 Power IN/OUT.

2.2.1.2 EC OUT

	Pin #	Signal Name	Pin #	Signal Name
 1,2 8	1	LAN2_TX+	2	LAN2_TX-
	3	LAN2_RX+	4	VS+
	5	VP+	6	LAN2_RX-
	7	VS- (GND)	8	VP- (GND)

* PoE LAN with the Red Housing; Regular LAN with Black Housing.

* L4, L5, L7, L8 pins are option, for RJ45 Power IN/OUT.

Note. QEC's PoE (Power over Ethernet)

In QEC product installations, users can easily distinguish between PoE and non-PoE: if the RJ45 house is red, it is PoE type, and if the RJ45 house is black, it is non-PoE type.

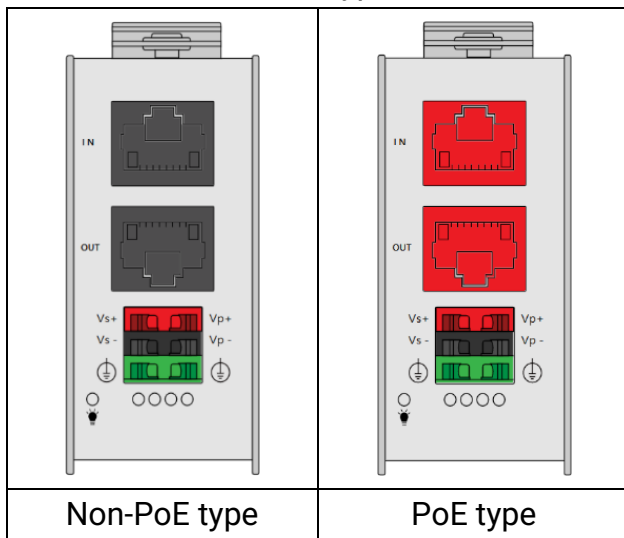

PoE (Power over Ethernet) is a function that delivers power over the network. QEC can be equipped with an optional PoE function to reduce cabling. In practice, PoE is selected based on system equipment, so please pay attention to the following points while evaluating and testing:

1. When connecting PoE and non-PoE devices, make sure to disconnect Ethernet cables at pins 4, 5, 7, and 8 (e.g., when a PoE-supported QEC EtherCAT MDevice connects with a third-party EtherCAT SubDevice).
2. The PoE function of QEC is different and incompatible with EtherCAT P, and the PoE function of QEC is based on PoE Type B, and the pin functions are as follows:

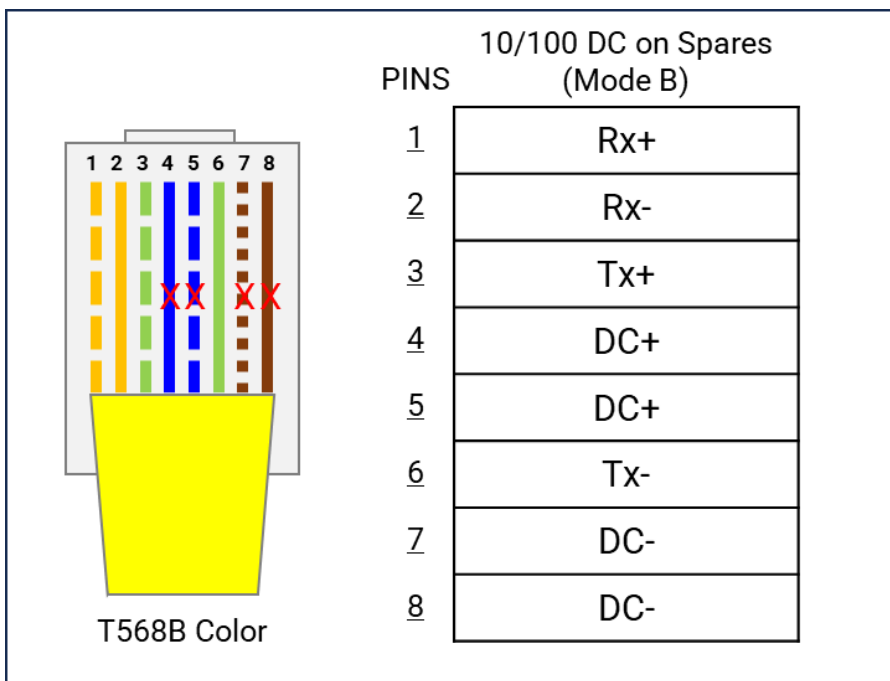

3. QEC's PoE power supply is up to **24V/3A**.

2.2.2 Power Connector

Euroblock Connectors.

4-pin Power Input/Output (+V: Red / GND: Black) and 2-pin FGND (Green).

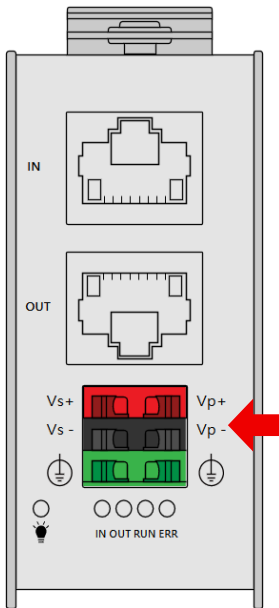

Vs for system power; Vp for peripheral power and backup power.

	Pin #	Signal Name	Pin #	Signal Name
	1	Vs+	2	Vp+
	3	Vs- (GND)	4	Vp- (GND)
	5	F.G	6	F.G

* Power Input voltage +19 to +50VDC Power Input (Typ. +24VDC)

2.2.3 Power and Connection Status LEDs

Power and connection status LEDs information.

2.2.3.1 Power Status LED

Power input is 24V (typical). The LED status provide high/low voltage warning.

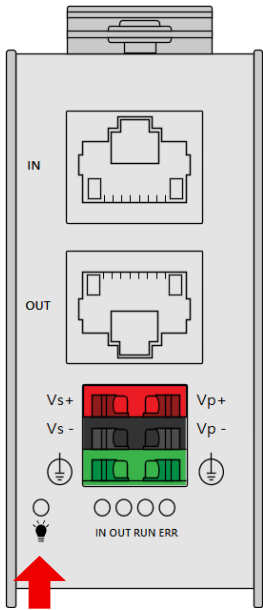

Notation	States	Condition	Description
PWR 	Green LED On	Voltage $\leq 50V$ and $\geq 45V$ Voltage $\leq 26V$ and $\geq 19V$	When Vs and Vp voltages are confirmed to be normal, the Green LED will remain steady on.
	Green LED On Red LED On	Voltage $< 45V$ and $> 26V$ Voltage $< 19V$ and $> 12V$	LEDs will alternately flash (at 0.3-second intervals) until the Vs and Vp voltages are correct.
	Orange LED On	Voltage $> 50V$ or $< 12V$	Orange LED (Green + Red) will continuously flash (at 0.3-second intervals) until the Vs and Vp voltages are correct.

* Vs power status will be displayed first.

Power ERROR Code table (Red LED Flashing Display (2 seconds/cycle)) :

Long Light	Short Flash	Description
0 Long Light		After microchip completes the Bootloader test, it proceeds to the APP program stage.
	1 short flash	Microchip communication with the EtherCAT chip failed.
	2 short flashes	EtherCAT chip internal RAM test failed.
	5 short flashes or 6 short flashes	Quartz oscillator on the board abnormality.
1 Long Light		Indicates the microchip Bootloader stage during startup, APP program not yet executed.
	1 short flash	microchip internal SRAM failed.
	2 short flashes	APP software CHECKSUM failed.
2 Long Lights	Not yet defined.	

* **Note:** If you encounter any of the above abnormal states, please contact us.

2.2.4 I/O Status LEDs

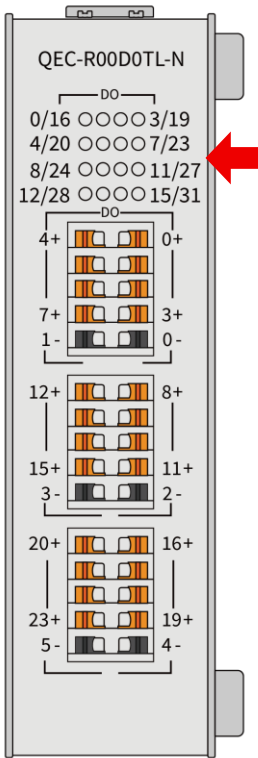

Notation	States	Color	Description
DI	Off	-	Digital input status is "Off"
	On	Orange	From 0 to 15 channel, Digital input status is "On"
		Blue	From 16 to 32 channel, Digital input status is "On"
		Purple	Both Digital input from 0 to 15 and 16 to 32 channels are "On"
DO	Off	-	Digital output status is "Off"
	On	Green	From 0 to 15 channel, Digital output status is "On"
		Blue	From 16 to 32 channel, Digital output status is "On"
		Purple	Both Digital output from 0 to 15 and 16 to 32 channels are "On"

2.2.4.1 LED Color Comparison

Orange	Blue	Purple

2.2.5 I/O Connector

For EtherCAT index assignments, refer to Section 5.2.3 Special Objects (0x6000–0xFFFF).

2.2.5.1 Digital Input (QEC-RXXDT0H/ QEC-RXXDT0L)

Connector color: Positive – Red / Negative – Black.

Each group of 4 input channels shares one COM pin. Connect all COM pins in a group to the same GND reference. See Section 2.3.3 for wiring details.

Front Side:

Pin #	Signal Name		Pin #	Signal Name
4+	DI04		0+	DI00
5+	DI05		1+	DI01
6+	DI06		2+	DI02
7+	DI07		3+	DI03
1-	COM (GND)		0-	COM (GND)
12+	DI12		8+	DI08
13+	DI13		9+	DI09
14+	DI14		10+	DI10
15+	DI15		11+	DI11
3-	COM (GND)		2-	COM (GND)
20+	DI20		16+	DI16
21+	DI21		17+	DI17
22+	DI22		18+	DI18
23+	DI23		19+	DI19
5-	COM (GND)		4-	COM (GND)

Bottom Side:

Pin #	Signal Name		Pin #	Signal Name
28+	DI28		24+	DI24
29+	DI29		25+	DI25
30+	DI30		26+	DI26
31+	DI31		27+	DI27
7-	COM (GND)		6-	COM (GND)

- Maximum load voltage: 40 VDC
- I/O Type: Sink (NPN)

2.2.5.2 Digital Output (QEC-RXXD0TH/ QEC-RXXD0TL)

Connector color: Positive – Orange / Negative – Black.

Each group of 4 output channels shares one COM pin. Connect all COM pins in a group to the same GND reference. See Section 2.3.3 for wiring details.

Front side:

Pin #	Signal Name		Pin #	Signal Name
4+	D004		0+	D000
5+	D005		1+	D001
6+	D006		2+	D002
7+	D007		3+	D003
1-	COM (GND)		0-	COM (GND)
12+	D012		8+	D008
13+	D013		9+	D009
14+	D014		10+	D010
15+	D015		11+	D011
3-	COM (GND)		2-	COM (GND)
20+	D020		16+	D016
21+	D021		17+	D017
22+	D022		18+	D018
23+	D023		19+	D019
5-	COM (GND)		4-	COM (GND)

Bottom side:

Pin #	Signal Name		Pin #	Signal Name
28+	D028		24+	D024
29+	D029		25+	D025
30+	D030		26+	D026
31+	D031		27+	D027
7-	COM (GND)		6-	COM (GND)

- Maximum load voltage: 40 VDC
- Maximum load current: 250 mA per channel
- I/O Type: Sink (NPN)

2.2.6 DIN-Rail installation

Please refer to [Ch.3.1 DIN-Rail installation](#).

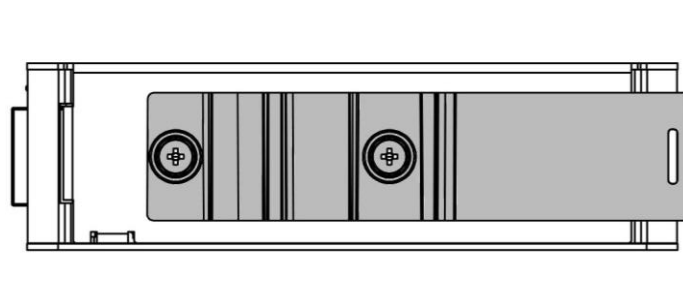
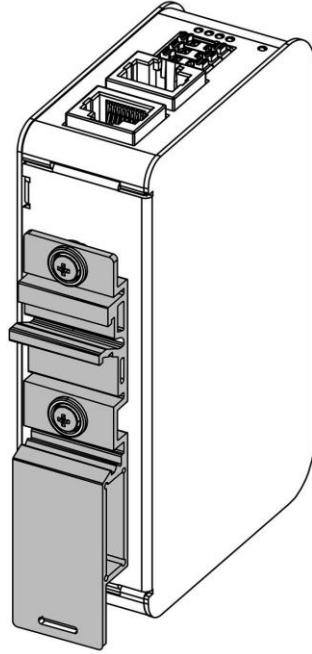

2.3 Wiring to the Connector

2.3.1 Connecting the wire to the connector

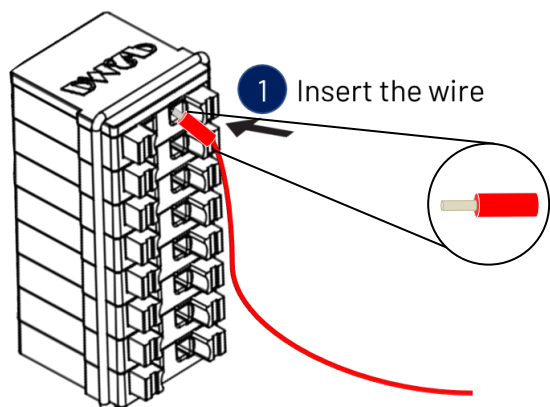

1 Insert the wire

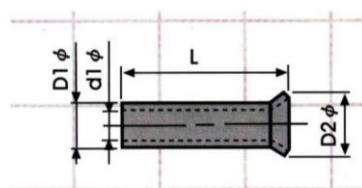

Insulated Terminals Dimensions (mm)

Position	L	ØD1	Ød1	ØD2
CN 0.5-6	6.0	1.3	1.0	1.9
CN 0.5-8	8.0	1.3	1.0	1.9
CN 0.5-10	10.0	1.3	1.0	1.9

2.3.2 Removing the wire from the connector

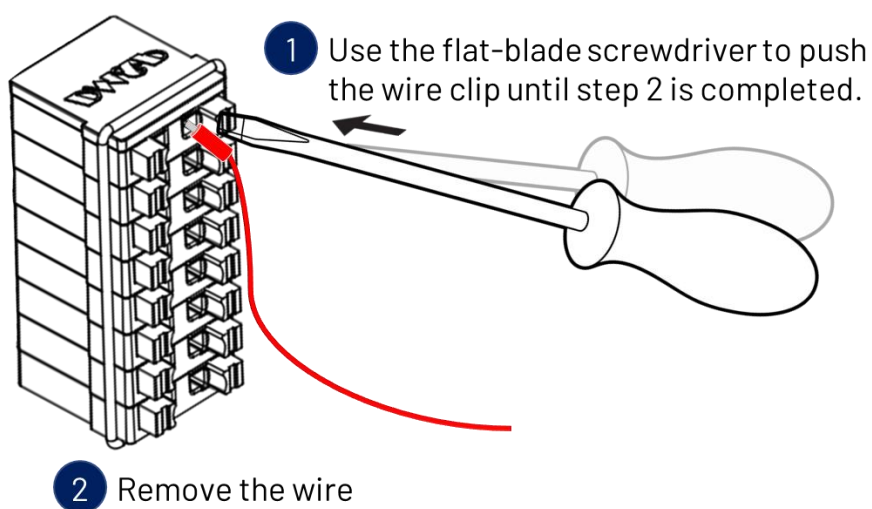

1 Use the flat-blade screwdriver to push the wire clip until step 2 is completed.

2 Remove the wire

2.3.3 Application Wiring

2.3.3.1 Digital Input (QEC-RXXDT0H / QEC-RXXDT0L)

The module uses a **Sink (NPN)** input circuit. Each group of 4 channels shares one COM pin connected to GND.

Wiring steps:

1. Connect the power supply positive (Typ. +24 VDC) to one terminal of the load (e.g., switch).
2. Connect the other terminal of the load to the DI+ pin.
3. Connect the COM (DI-) pin of the same group to GND.
4. Repeat for each channel group using the corresponding COM pin.

Signal voltage: Typ. +24 VDC.

Internal ISO1212 chips provide reliable signal detection and up to 2,500 Vrms optical isolation.

*** Important Note:** Each COM pin serves exactly 4 channels. Do not share COM pins across groups or mix GND references within the same group. Incorrect wiring will cause signal errors or permanent module damage.

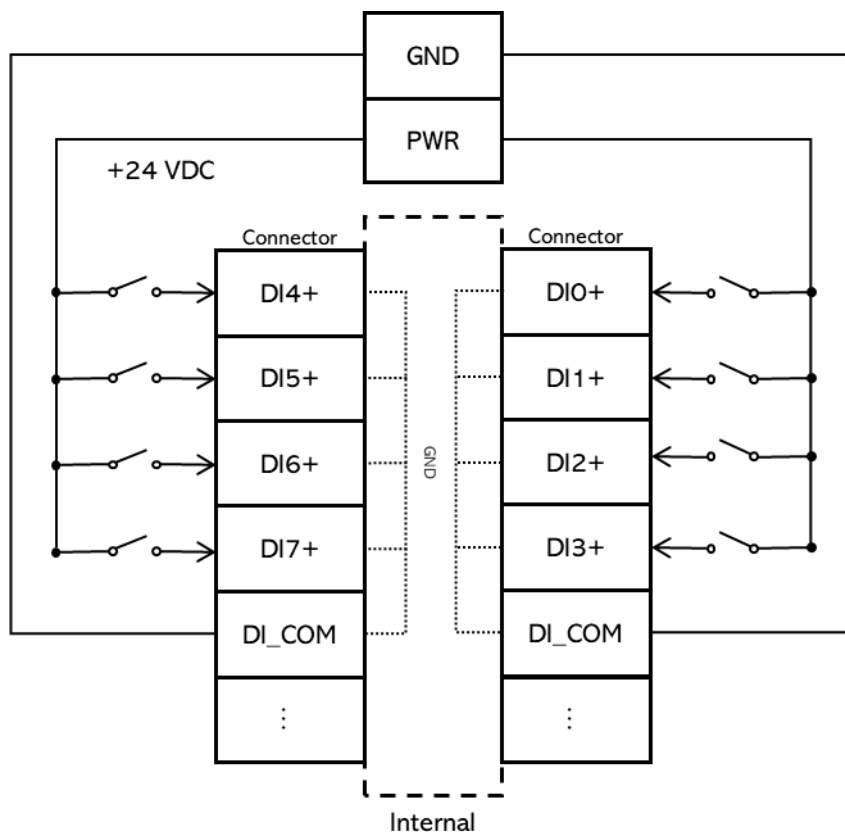

Figure shows one channel group (4 channels + 1 COM) as a representative example. All 32 channels follow the same wiring pattern.

Channel-to-COM Reference

Front Side:

Pin #	Signal Name		Pin #	Signal Name
4+	DI04	<p>Diagram showing front side pin headers with connections for pins 4+ through 5-. The diagram is divided into three sections: pins 4+ to 7+, pins 12+ to 15+, and pins 20+ to 23+. Each section shows a pair of pins with a red and a black header, and a corresponding signal name to the right.</p>	0+	DI00
5+	DI05		1+	DI01
6+	DI06		2+	DI02
7+	DI07		3+	DI03
1-	COM (GND)		0-	COM (GND)
12+	DI12		8+	DI08
13+	DI13		9+	DI09
14+	DI14		10+	DI10
15+	DI15		11+	DI11
3-	COM (GND)		2-	COM (GND)
20+	DI20		16+	DI16
21+	DI21		17+	DI17
22+	DI22		18+	DI18
23+	DI23		19+	DI19
5-	COM (GND)		4-	COM (GND)

Bottom Side:

Pin #	Signal Name		Pin #	Signal Name
28+	DI28	<p>Diagram showing bottom side pin headers with connections for pins 28+ through 7-. The diagram shows a pair of pins with a red and a black header, and a corresponding signal name to the right.</p>	24+	DI24
29+	DI29		25+	DI25
30+	DI30		26+	DI26
31+	DI31		27+	DI27
7-	COM (GND)		6-	COM (GND)

2.3.3.2 Digital Output (QEC-RXXD0TH / QEC-RXXD0TL)

The module uses a **Sink (NPN)** output circuit with MOSFET switching. Each group of 4 channels shares one COM pin connected to GND.

Wiring steps:

1. Connect the power supply positive (Typ. +24 VDC.VDC) to one terminal of the load.
2. Connect the other terminal of the load to the DO+ pin.
3. Connect the COM (DO-) pin of the same group to GND.
4. When the channel is activated by EtherCAT, the internal MOSFET closes the circuit and current flows through the load.

Load voltage: Typ. +24 VDC.

Maximum load current: 250 mA per channel.

Each channel incorporates a photocoupler and MOSFET for signal isolation and output switching.

*** Important Note:** Do not exceed 250 mA per channel. Each COM pin serves exactly 4 channels — do not mix groups or GND references. Overloading or incorrect wiring will permanently damage the MOSFET output stage.

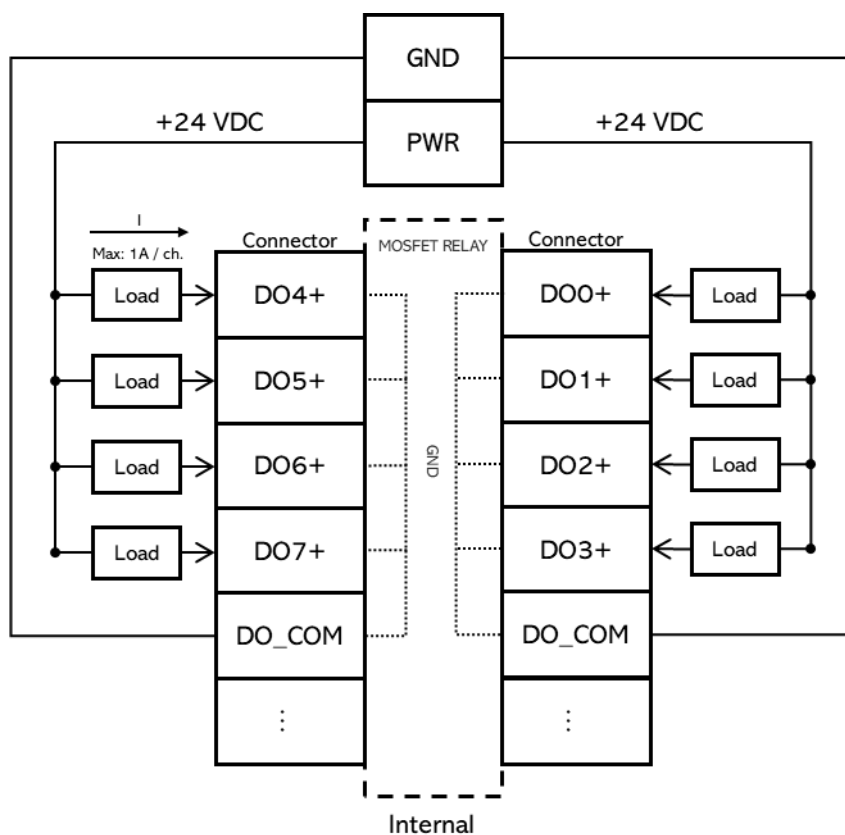

Figure shows one channel group (4 channels + 1 COM) as a representative example. All 32 channels follow the same wiring pattern.

Channel-to-COM Reference

Front side:

Pin #	Signal Name		Pin #	Signal Name
4+	D004		0+	D000
5+	D005		1+	D001
6+	D006		2+	D002
7+	D007		3+	D003
1-	COM (GND)		0-	COM (GND)
12+	D012		8+	D008
13+	D013		9+	D009
14+	D014		10+	D010
15+	D015		11+	D011
3-	COM (GND)		2-	COM (GND)
20+	D020		16+	D016
21+	D021		17+	D017
22+	D022		18+	D018
23+	D023		19+	D019
5-	COM (GND)		4-	COM (GND)

Bottom side:

Pin #	Signal Name		Pin #	Signal Name
28+	D028		24+	D024
29+	D029		25+	D025
30+	D030		26+	D026
31+	D031		27+	D027
7-	COM (GND)		6-	COM (GND)



Ch. 3

Hardware Installation

This section describes how to install QEC-RXXD. Please turn OFF the power supply before you mount QEC-RXXD. Always mount QEC-RXXD one at a time.

3.1 DIN-Rail installation

Slide in the QEC-RXXD on the hookup guides and press the QEC-RXXD with a certain amount of force against the DIN track until the DIN Track mounting hook lock into place.

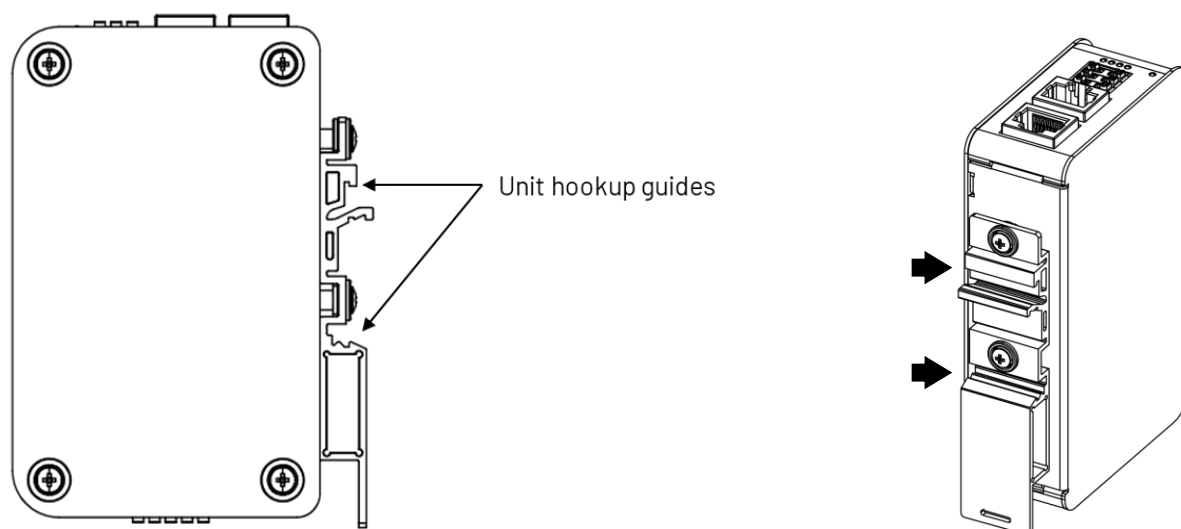

When you mount the QEC-RXXD, releasing the DIN track mounting hook on the QEC-RXXD is unnecessary. After you mount the QEC-RXXD, make sure it is locked to the DIN Track.

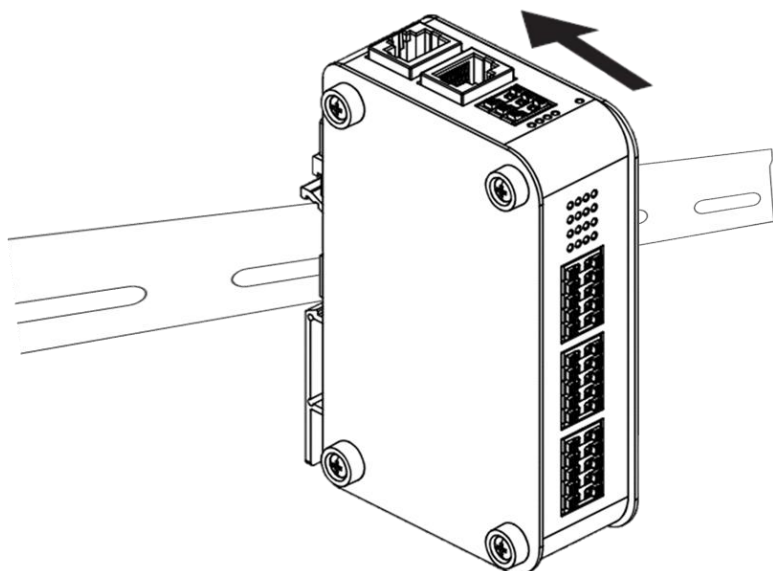

*** Note:** Always turn OFF the Unit power supply and I/O power supply before connecting and removing the QEC-RXXD.

3.2 Removing QEC-RXXD Unit

Use a flat-blade screwdriver to remove the DIN Track mounting hook on the unit.

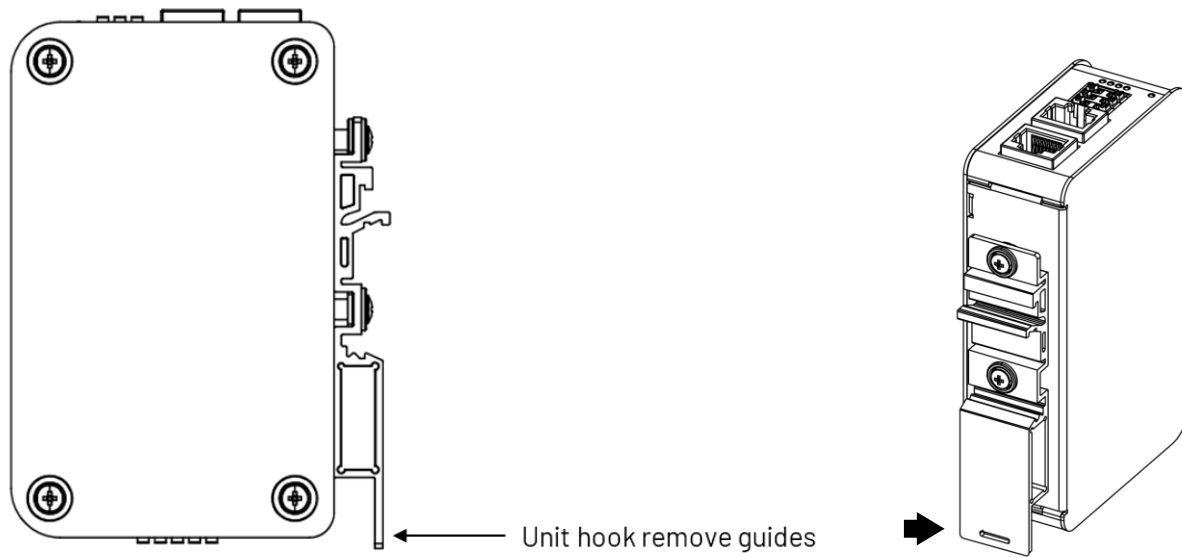

Pull down and out the flat-blade screwdriver with force against the DIN track until you hear the DIN Track remove the hook.

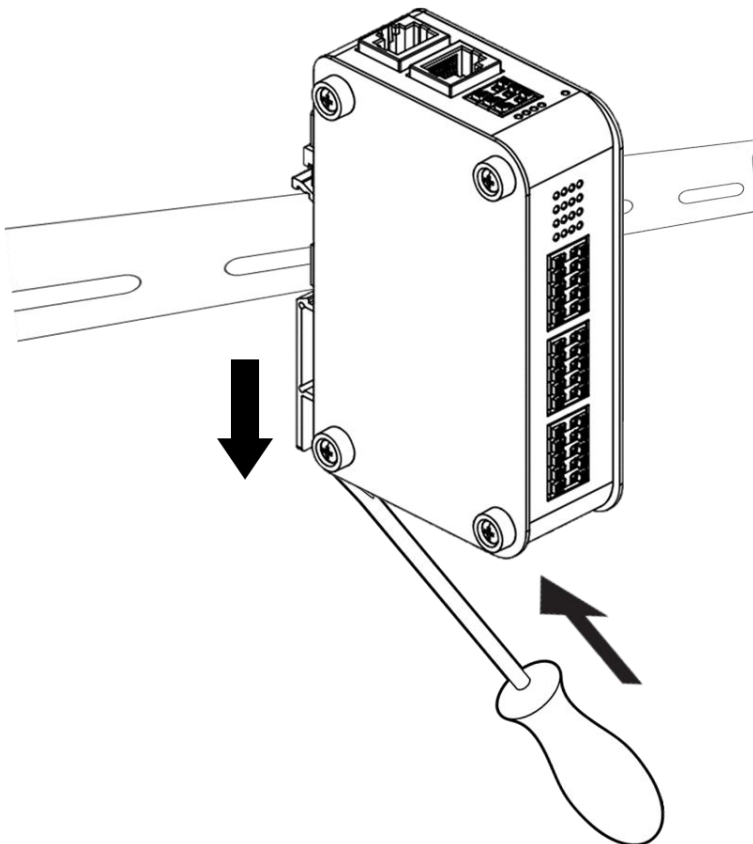



Ch. 4

Getting Started

4.1 Introduction

Welcome to the Getting Started Chapter for the QEC-RXXDT0 and QEC-RXXD0T modules. This section is designed to assist you in efficiently setting up and utilizing them.

To facilitate this process, we will focus on two development paths are supported:

- QEC-M + 86Duino IDE – ICOP's integrated EtherCAT development environment
- Third-party EtherCAT MainDevice (e.g., TwinCAT by Beckhoff) – via ESI file and standard EtherCAT configuration

*** Note: QEC PoE (Power over Ethernet)**

QEC devices can be identified by RJ45 housing color: **red = PoE, black = non-PoE.**

- When connecting PoE and non-PoE devices, disconnect Ethernet cable pins 4, 5, 7, and 8.
- QEC PoE is based on **PoE Type B** and is **not compatible with EtherCAT P.**
- QEC PoE power supply: up to **24 V / 3 A.**

*** Note: Ensuring Up-to-date Installation of the XML Device Description File (ESI)**

To ensure smooth functioning, it is important to install the latest version of the XML device description file in the EtherCAT MDevice software. The latest version of the XML device description file can be downloaded from the QEC website.

<https://www.qec.tw/>

4.2 QEC-M + 86Duino IDE

4.2.1 Hardware Preparation and Connection

The following devices are used here:

1. QEC-M-01P (EtherCAT MainDevice/PoE)
2. QEC-R11D0TH-N (EtherCAT High-speed 32-ch digital output/PoE)
3. QEC-R11DT0H-N (EtherCAT High-speed 32-ch digital input/PoE)
4. RJ45 cable
5. 24V power supplier



Supply +19 to +50 VDC to the Vs+/Vs- and Vp+/Vp- terminals on QEC-M-01P. All other QEC devices in this example are powered via PoE. After power-on, verify that the **PWR** LED on each device is green.

Connect the devices in a line topology:

1. QEC-M-01P **EC OUT** → QEC-R11DT0H-N **EC IN**
2. QEC-R11DT0H-N **EC OUT** → QEC-R11D0TH-N **EC IN**

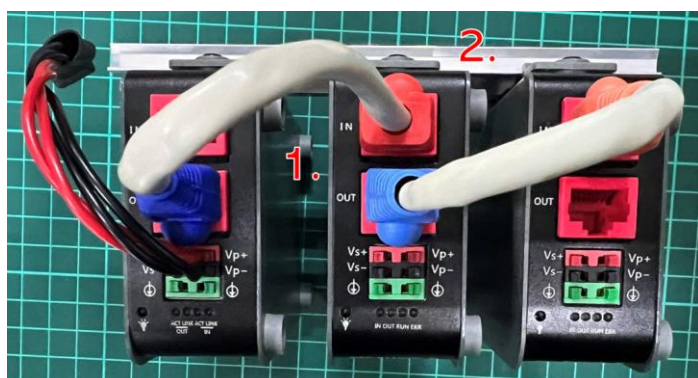

4.2.2 Software/Development Environment

Download 86duino IDE from <https://www.qec.tw/software/>.

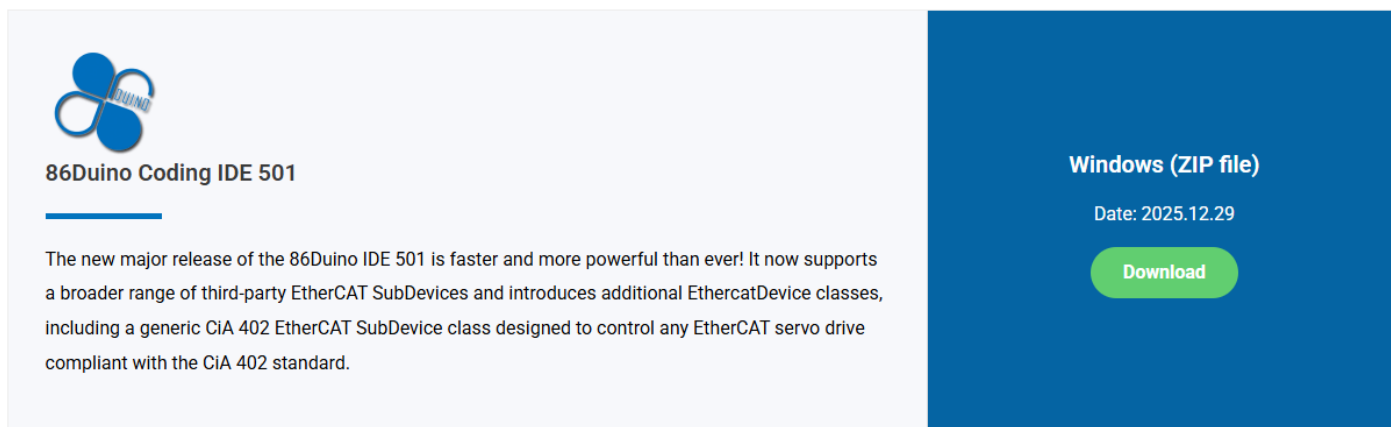

86duino Coding IDE 501

The new major release of the 86duino IDE 501 is faster and more powerful than ever! It now supports a broader range of third-party EtherCAT SubDevices and introduces additional EthercatDevice classes, including a generic CiA 402 EtherCAT SubDevice class designed to control any EtherCAT servo drive compliant with the CiA 402 standard.

Windows (ZIP file)
Date: 2025.12.29
[Download](#)

After downloading, please unzip the downloaded zip file, no additional software installation is required, just double-click **86duino.exe** to start the IDE.



* **Note:** If Windows displays a warning, click Details once and then click the Continue Run button once.

86duino Coding IDE 501+ looks like below.



4.2.3 Connect to your PC and set up the environment

Follow the steps below to set up the environment:

1. Connect the QEC-M-01 to your PC via a Micro USB to USB cable (86Duino IDE installed).
2. Turn on the QEC power.
3. Open **"Device Manager"** (select in the menu after pressing Win+X) -> **"Ports (COM & LPT)"** in your PC and expand the ports; you should see that the **"Prolific PL2303GC USB Serial COM Port (COMx)"** is detected; if not, you will need to install the required drivers.
(For Windows PL2303 driver, you can download [here](#))

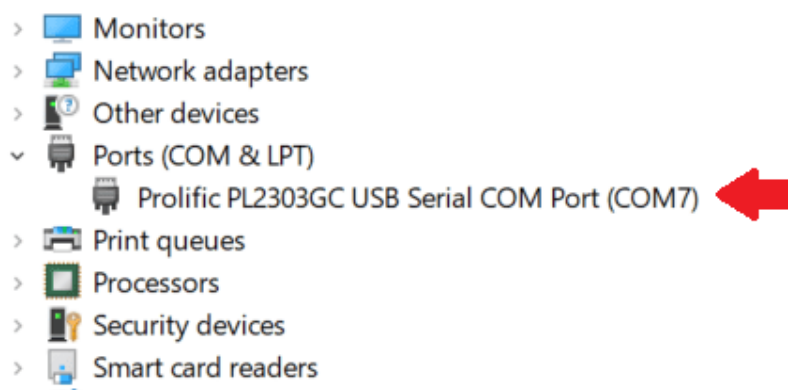
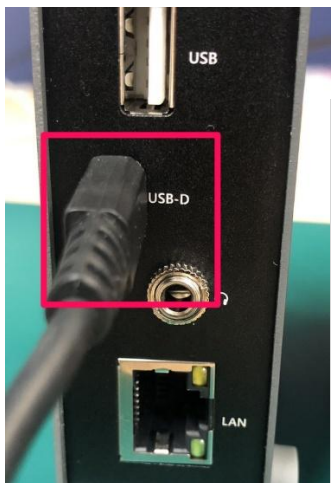

4. Open the 86Duino IDE.
5. Select the correct board: In the IDE's menu, select **"Tools" > "Board" > "QEC-M01"** (or the QEC MDevice model you use).
6. Select Port: In the IDE's menu, select **"Tools" > "Port"** and select the USB port to connect to the QEC MDevice (in this case, COM9 (QEC)).

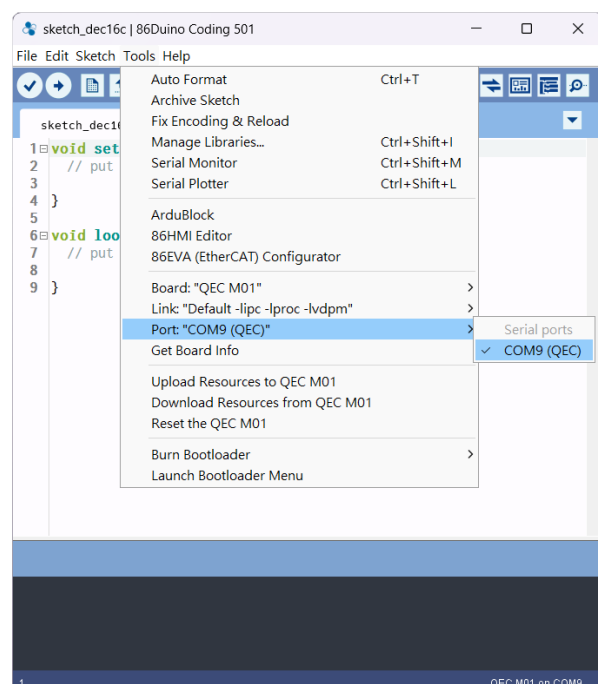
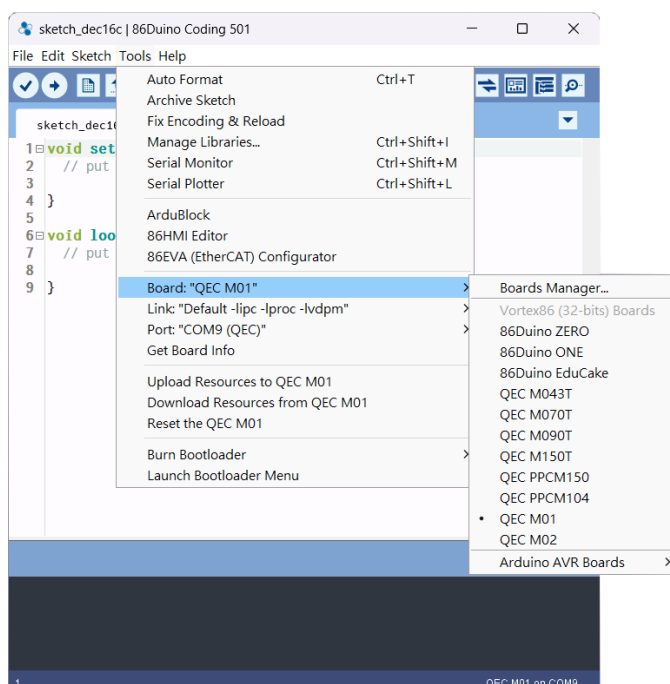

4.2.4 Configuration and Operation

86EVA is a graphical EtherCAT configurator based on the EtherCAT Library in the 86Duino IDE and is one of the development kits for 86Duino. The user can use it to configure the EtherCAT network quickly and start programming.

4.2.4.1 Step 1: Turn on 86EVA and scan

The 86EVA tool can be opened via the following buttons.

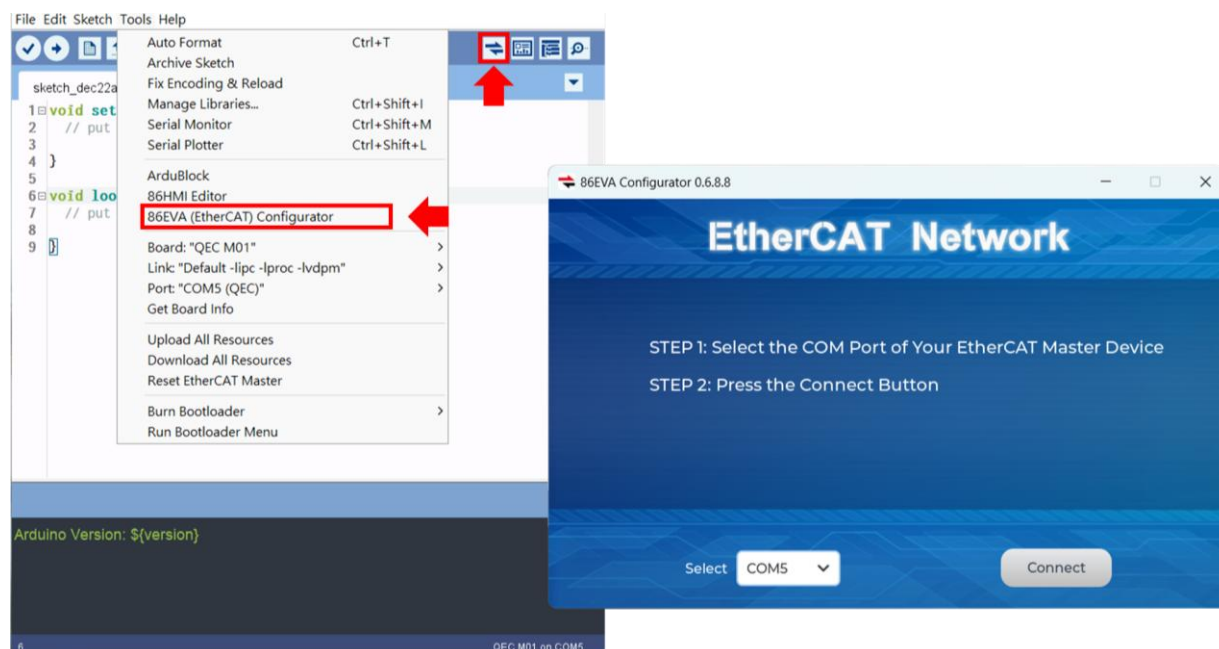

Once you have confirmed that the correct COM port has been selected of QEC-M-01, press the **“Connect”** button to start scanning the EtherCAT network.



4.2.4.2 Step 2: Set the parameters

The connected devices will be displayed after the EtherCAT network has been scanned.

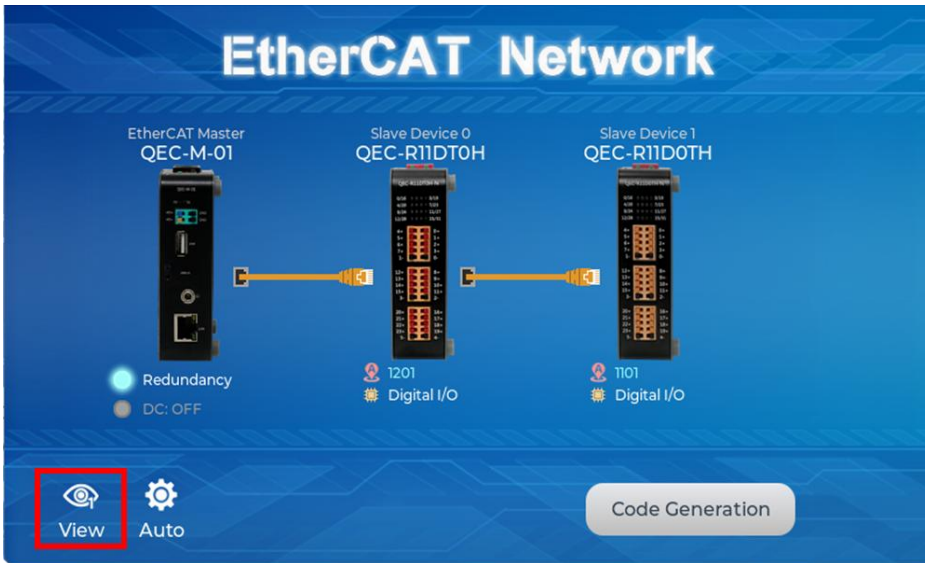

You can press twice on the scanned device image to enter the corresponding parameter setting screen. There are including the Device Name, Object Name, Alias Address, Vendor ID, and Product Code of the QEC SubDevices.

QEC-R11DT0H



QEC-R11D0TH



4.2.4.3 Step 3: Generation the code

After configuring all settings, click the "Code Generation" button.

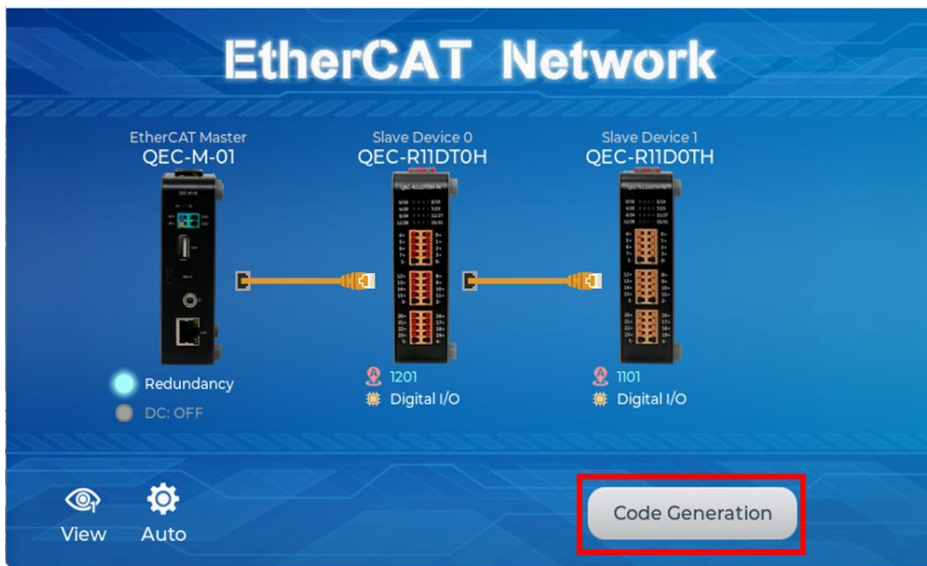

After clicking, the result and completion screen will appear, click **OK** to leave the program; If you do not click OK, you will leave the program after 10 seconds.

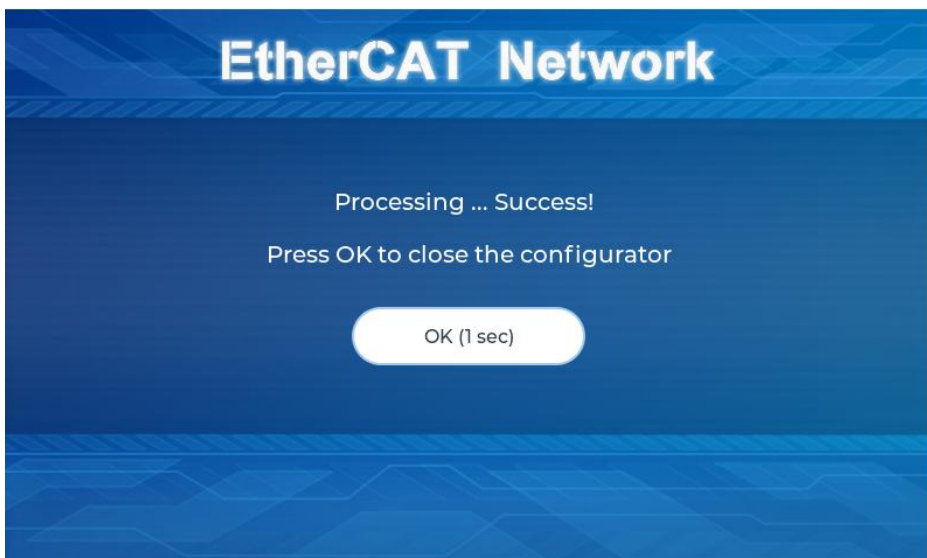

The generated code and files are as follows:

- sketch_dec22b: Main Project (depends on your project name)
- ChatGPT.h: Parameters to provide to ChatGPT referred
- myeva.cpp: C++ program code of 86EVA
- myeva.h: Header file of 86EVA





```
1 #include "myeva.h"
2 void setup() {
3   EVA.begin();
4   // put your setup code here, to run once:
5
6 }
7
```

*** Additional Note:** After 86EVA generates code, the following code will be automatically generated in the main program (.ino), and any of them will cause 86EVA not to work.

1. `#include "myeva.h"` : Include EVA Header file
2. `EVA.begin()` in `setup()`; : Initialize the EVA function

4.2.4.4 Step 4: Upload the code

Once the code is generated, click on the toolbar to  compile, and to confirm that the compilation is complete and error-free, you can click  to upload. The program will run when the upload is complete.



After the upload, if the EtherCAT Network is running successfully, it will enter OPERATION mode. You can confirm this by the RUN LED on your QEC SubDevices, which should light up. Additionally, the LED on the EtherCAT LAN ports will start blinking, indicating active operation.

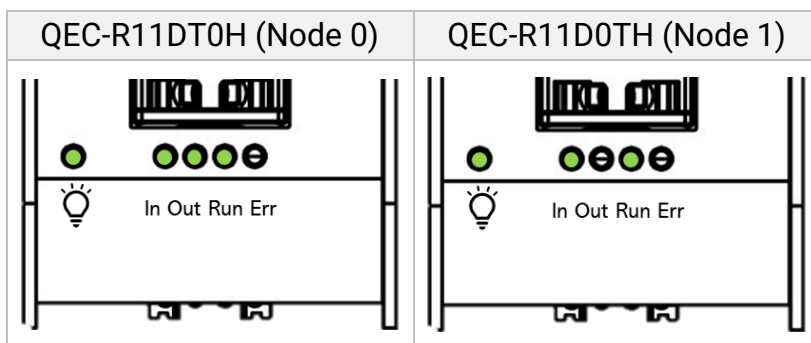

4.2.5 EthercatDevice_QECRXXD Class

This class provides access to QEC-RXXD digital I/O functions within the EtherCAT Library.

Initialization (all models)

- `attach()` – Assign SubDevice node number to the EtherCAT MainDevice.

Internal Monitoring (QEC-RXXDT0H / QEC-RXXD0TH only)

- `getSystemTemperature()`
- `getSystemPowerVoltage()` / `getSystemPowerCurrent()`
- `getPeripheralPowerVoltage()` / `getPeripheralPowerCurrent()`

Digital Input (QEC-RXXDT0H / QEC-RXXDT0L)

- `digitalRead()` – Read a single channel
- `digitalReadAll()` – Read all 32 channels at once

Digital Output (QEC-RXXD0TH / QEC-RXXD0TL)

- `digitalWrite()` – Set a single channel HIGH or LOW
- `digitalWriteAll()` – Set all 32 channels simultaneously

Distributed Clock – DC Mode (H models only)

- `setDC()` – Configure DC synchronization parameters

For full API documentation, visit <https://www.qec.tw/ethercat/api/dmp/dio/>.

4.2.5.1 Example 1: Digital Read

Example for basic digital input operations.

Suppose your device is named **Slave0**. In this case, the code to read would be implemented as follows:

- To read the digital input from the all pins: `Slave0.digitalRead();`
- To print out as the serial monitor: `Serial.println(Slave0.digitalRead());`

86EVA Object Definition:



Your code:

```

1 #include "myeva.h" // 86EVA
2
3 void setup() {
4   EVA.begin(); // Initialize the EVA
5   // put your setup code here, to run once:
6   Serial.begin(115200); // Start serial communication at 115200 baud rate
7 }
8
9 void loop() {
10  // put your main code here, to run repeatedly:
11  for (int i = 0; i < 32; i++) {
12    // Read and print the digital state of each pin from 0 to 31 on Slave0
13    Serial.print(Slave0.digitalRead(i));
14    // Add a newline character after printing the last pin's state
15    if (i == 31) Serial.println(Slave0.digitalRead(i));
16  }
17 }

```

When the code runs, it prints all the digital pins (0 to 31) of Slave0 on the Serial monitor in 86Duino IDE.

4.2.5.2 Example 2: Digital Write

Example for basic digital output operations.

Suppose your device is named **Slave1**. In this case, the code to set digital output pin would be implemented as follows:

- To set the all digital out pins to HIGH: `Slave1.digitalWrite(pins, HIGH);`
- To set the all digital out pins to LOW: `Slave1.digitalWrite(pins, LOW);`

86EVA Object Definition:



Your code:

```

1 #include "myeva.h" // 86EVA
2
3 void setup() {
4   EVA.begin(); // Initialize the EVA
5 }
6
7 void loop() {
8   // Loop to set all pins from 0 to 31 on Slave1
9   for (int i = 0; i < 32; i++) {
10    // Set the all digital output pin on Slave1 to HIGH
11    Slave1.digitalWrite(i, HIGH);
12  }
13  delay(1000); // Wait for 1 second
14
15  for (int i = 0; i < 32; i++) {
16    // Set the all digital output pin on Slave1 to LOW
17    Slave1.digitalWrite(i, LOW);
18  }
19  delay(1000); // Wait for 1 second
20 }

```

When the code runs, it turns on all the digital pins (0 to 31) on Slave1 at the same time. They stay on for 1 second. Then, all the pins are turned off and stay off for another second. This pattern of turning all pins on and then off again repeats continuously.

4.2.5.3 Example 3: Distributed Clock (DC)

For high-speed QEC DIO modules, you might need to configure the DC mode.

For instance, to set the DC mode on a device named Slave0: `Slave0.setDc(cycleTime0_ns);`
In this example code, we also attach the cyclic Callback function and set the EtherCAT SYNC mode.

```

1  #include "Ethercat.h" // Include the EtherCAT library
2
3  EthercatMaster EcatMaster; // Create an EtherCAT Master Object
4  EthercatDevice_QECR11DT0H Slave0; // Create an EtherCAT Slave Object for QEC-R11DT0H
5  EthercatDevice_QECR11D0TH Slave1; // Create an EtherCAT Slave Object for QEC-R11D0TH
6
7  // Define a callback function for cyclic tasks
8  void myCallback() {
9      // put your cyclic Callback function here.
10     // This function is called cyclically by the EtherCAT master
11 }
12
13 void setup() {
14     // Initialize the EtherCAT Master. If successful, all slaves enter PRE-OPERATIONAL state
15     EcatMaster.begin();
16
17     // Attach Slave0 to the EtherCAT Master at position 0 and set its Distributed Clock (DC)
18     Slave0.attach(0, EcatMaster);
19     Slave0.setDc(1000000); // Set DC cycle time to 1ms
20
21     // Attach Slave1 to the EtherCAT Master at position 1 and set its DC
22     Slave1.attach(1, EcatMaster);
23     Slave1.setDc(1000000); // Set DC cycle time to 1ms
24
25     // Attach the cyclic callback function to the EtherCAT Master
26     EcatMaster.attachCyclicCallback(myCallback);
27
28     // Start the EtherCAT Master with a cycle time of 1ms, using ECAT_SYNC mode
29     EcatMaster.start(1000000, ECAT_SYNC);
30 }
31
32 void loop() {
33     // put your main code here, to run repeatedly:
34     // This loop remains empty as EtherCAT communication is handled in the callback
35 }

```

Further Information on Distributed Clock (DC): To gain a deeper understanding of the Distributed Clock (DC) functionality in the EtherCAT protocol, consider visiting the [EtherCAT Device Protocol Poster](#) provided by the [EtherCAT Technology Group, ETG](#).

4.3 Third-Party EtherCAT MainDevice (e.g., TwinCAT)

The QEC-RXXD modules are standard EtherCAT SubDevices and are compatible with any ETG-compliant MainDevice software. The following procedure uses **TwinCAT 3 by Beckhoff** as an example.

*** Note:** The QEC-R11D88K used in this section is a separate product provided as a TwinCAT configuration example. The procedures described here apply equally to QEC-RXXDT0H and QEC-RXXD0TH modules.

4.3.1 Install the ESI file

1. Obtain the ESI file: The ESI file for the QEC-R11D88K module is located on our website at the following link: <https://www.qec.tw/>.
Simply download the ZIP file and extract it.
2. Install the ESI file: Once extracted, the XML file must be copied or moved to the appropriate system directory.
3. Restart the Programming System If Needed: If the TwinCAT program was running when the ESI file was copied to the appropriate system directory, you may have to restart the TwinCAT program before it will recognize the new ESI file.

4.3.2 Add the QEC-R11D88K to the Project

This section assumes that the TwinCAT software is in Config Mode.

For more information about TwinCAT, please refer to [TwinCAT | Automation software | Beckhoff Worldwide](#), or contact Beckhoff Automation.

1. Click the New Project.

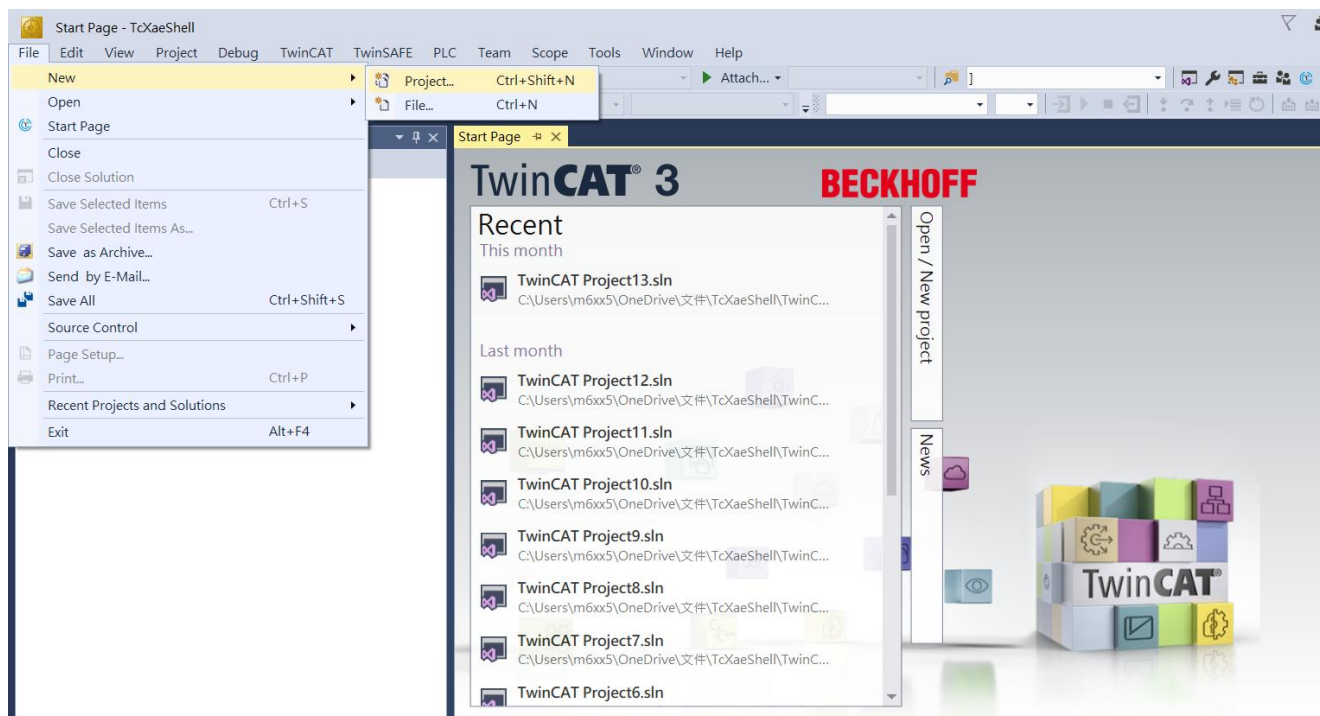

2. Select the “TwinCAT XAE Project (XML format)”, and change the project file name and location if you need. Then click “OK”.

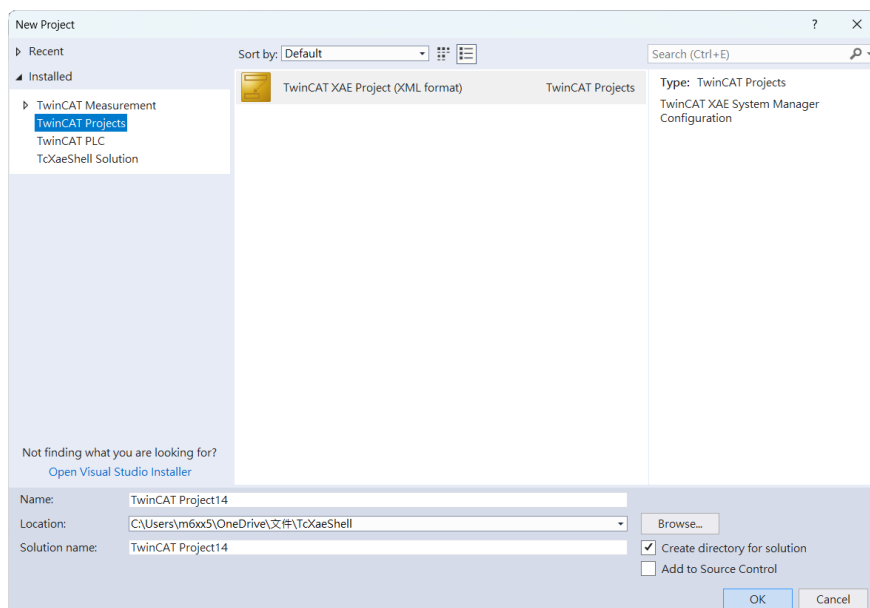

- Right-click the **"Devices"** under the I/O node, and click the **"Scan"** button to start scanning. (If the **"Scan"** option is not available, the TwinCAT software is not in Config Mode.)

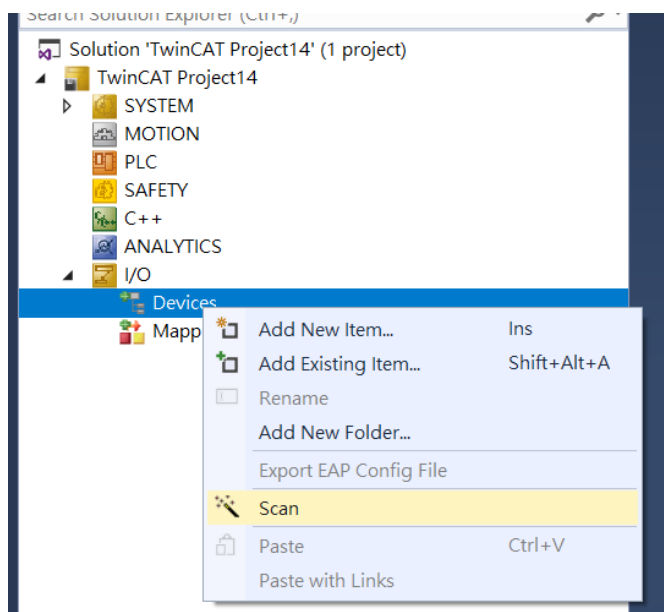

- Click **"OK"** for the HINT message.

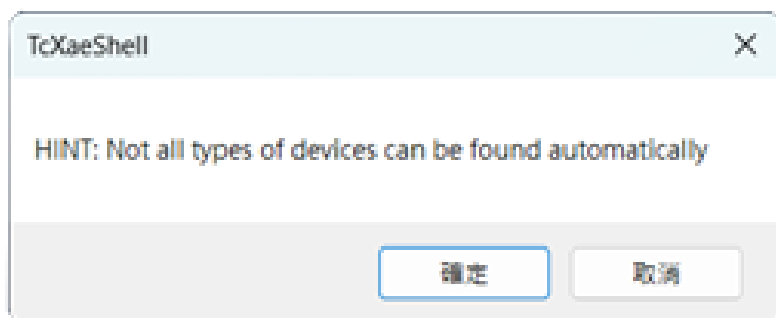

- Choose the EtheCAT connection network.

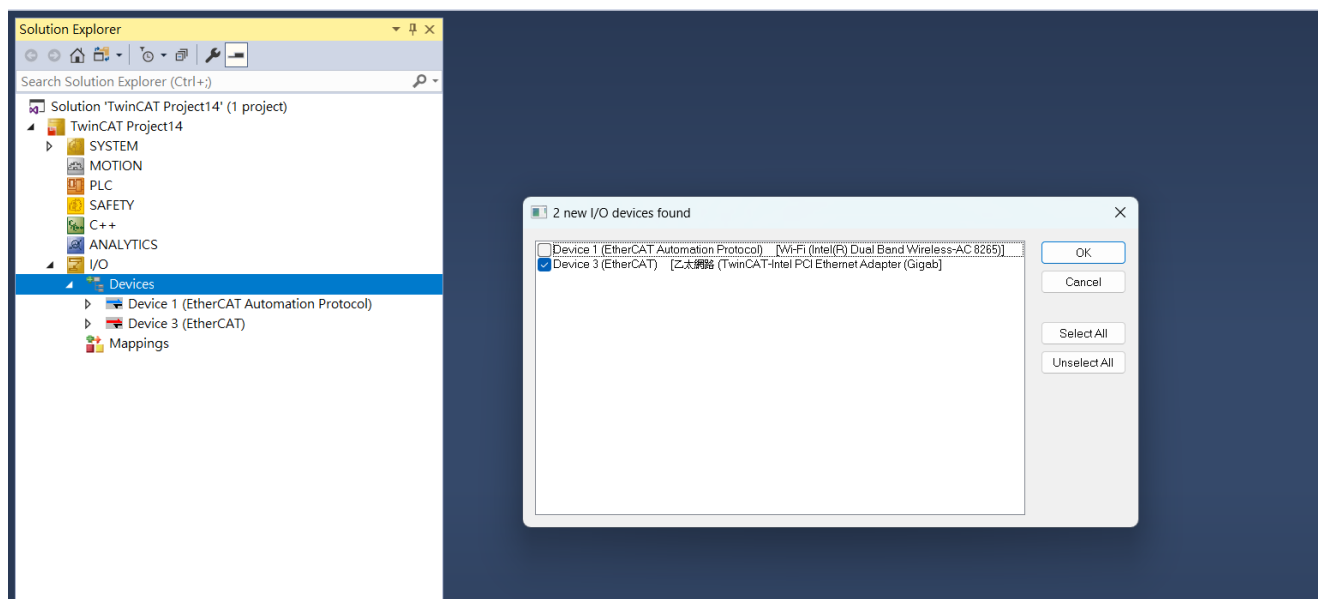

6. Confirm **“Yes”** to start the scan.

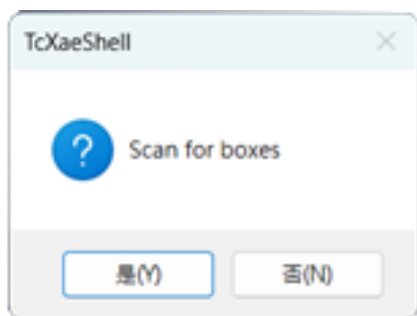

7. Choose **“Yes”** when TwinCAT asks you the new device type found.

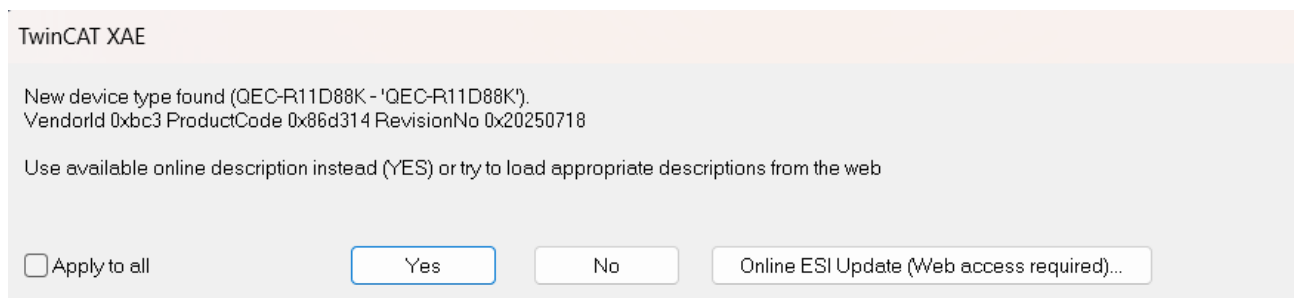

8. Choose **“Yes”** when TwinCAT asks you to activate Free Run.
Then, EtherCAT Network will translate into OP state automatically.

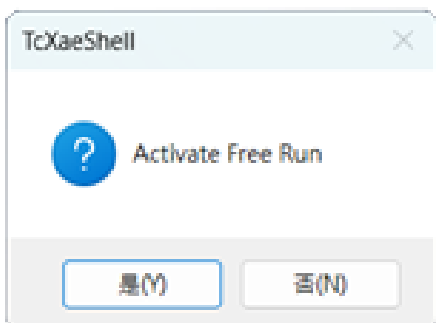

9. The QEC-R11D88K will appear in the device tree and the name will typically begin with **“Box”**.

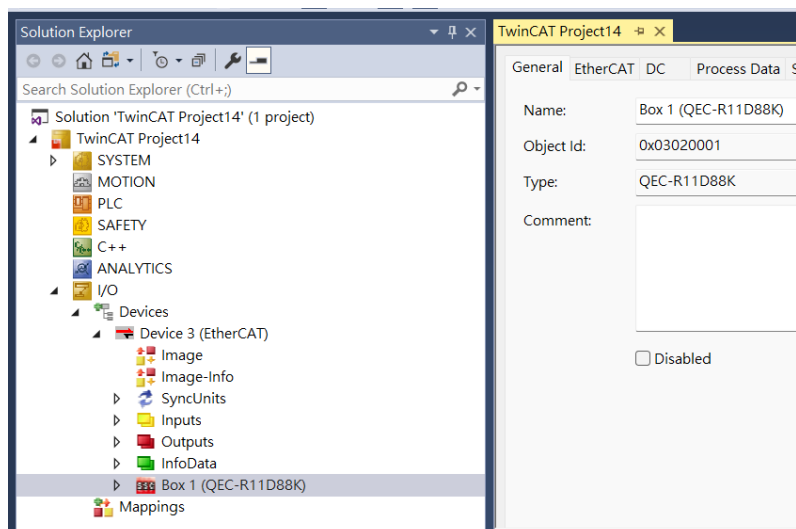

4.3.3 Start to Configure the QEC-R11D88K

1. Click "**Box 1 (QEC-R11D88K)**," and a dashboard for the EtherCAT SubDevice will appear in the right window.

The default tab is “**General**”, and you can see the SubDevice’s Name, Object Id, Type, and Comment in this tab.

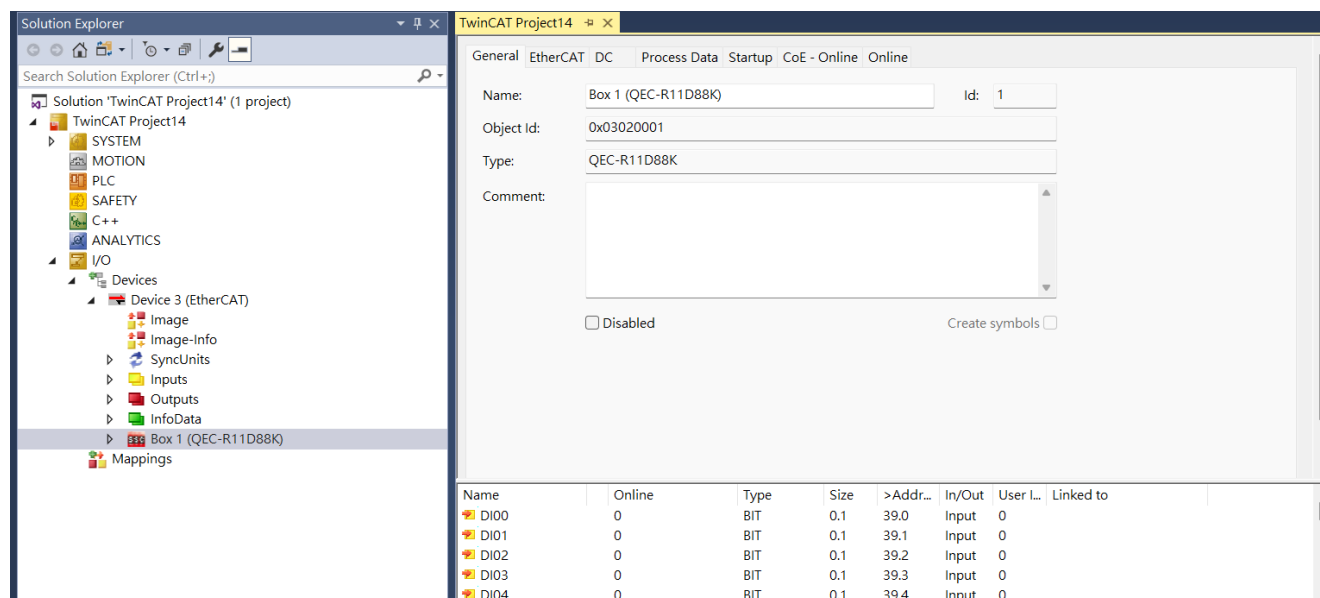

2. Click on the “**Online**” tab to check the EtherCAT SubDevice EtherCAT State Machine (ESM) is on OP status.

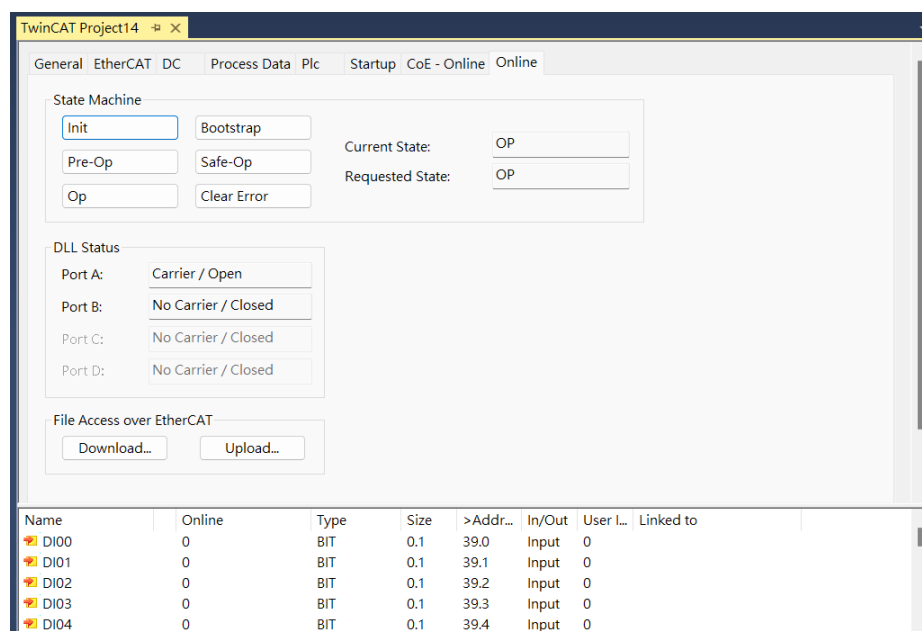

- Click on the **“Process Data”** tab to check the PDO Assignment; the default PDO Output are Digital Output Index (0x7000) and Analog Output Index (0x7001), and PDO Input are Digital Input Index (0x6000) and Analog Input Index (0x6001).

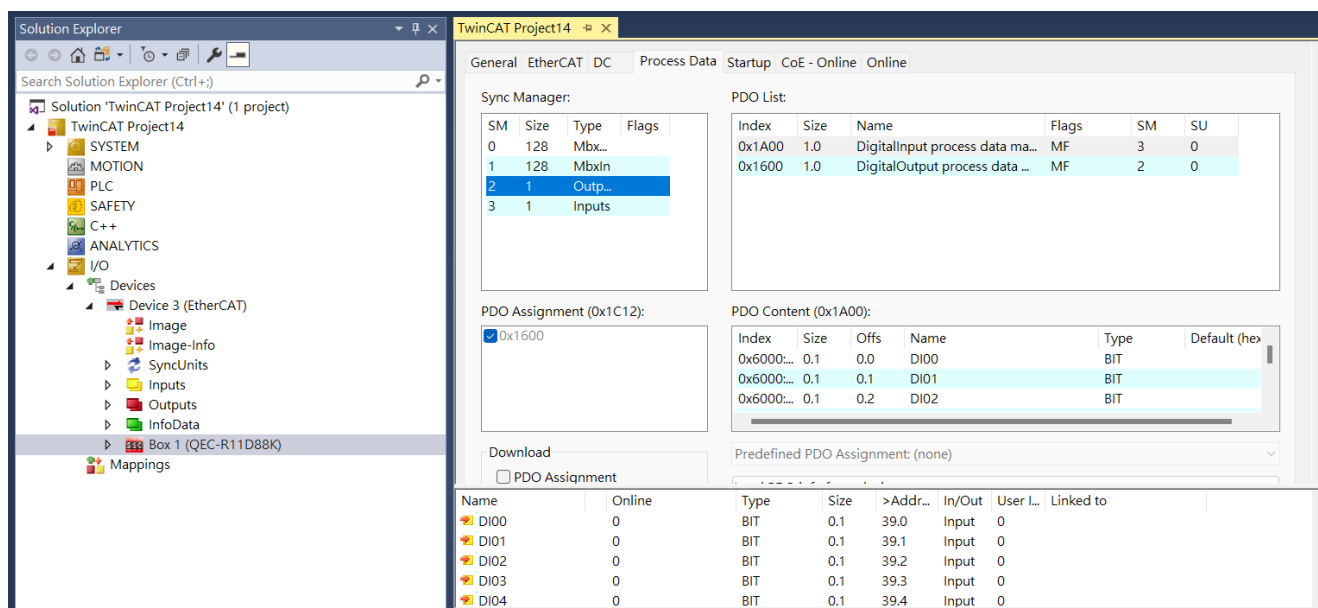

4.3.4 Control the QEC-R11D88K

Next, we will set the Digital Output channel 0 "DQ00" to 1 to let it pull high. And then we will read the Digital Input channel 0 "DI00".

4.3.4.1 Configure the Digital Output

Configure the Digital Output.

1. Select the drop-down list of the "Output mapping 0". Click the "DQ00" and it'll appear control dashboard in the right windows.

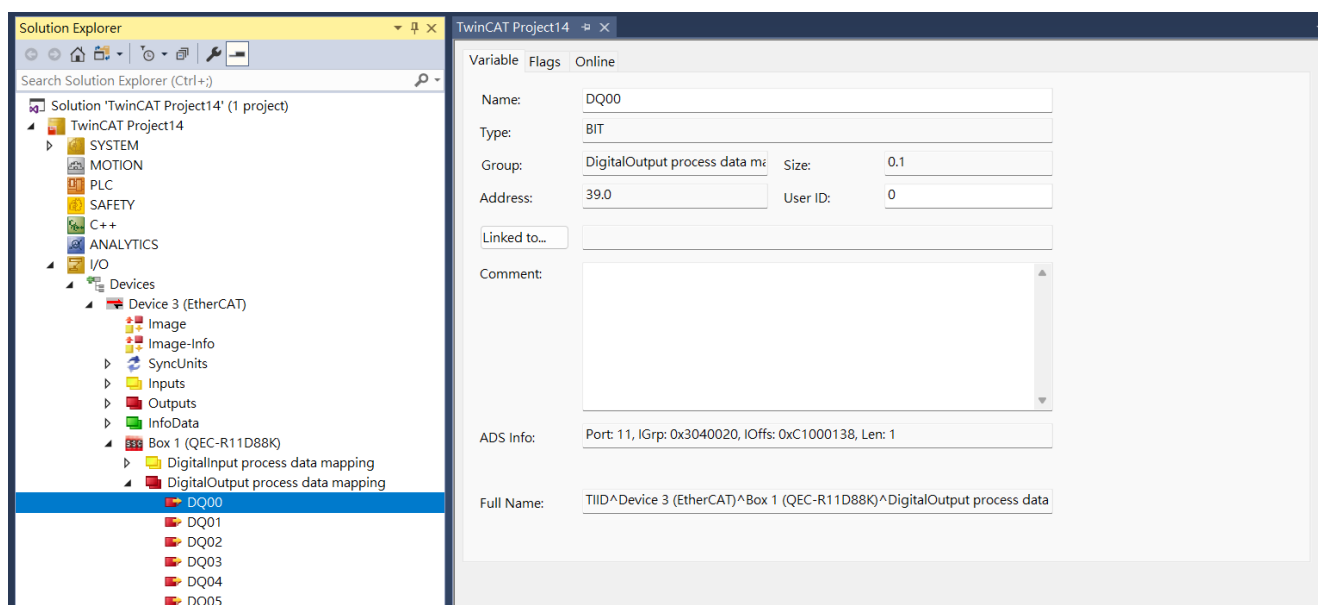

2. Click the "Online" tab, and click the "Write..." button. Enter "1" in the pop-up window to change the value of DQ00 to "1".

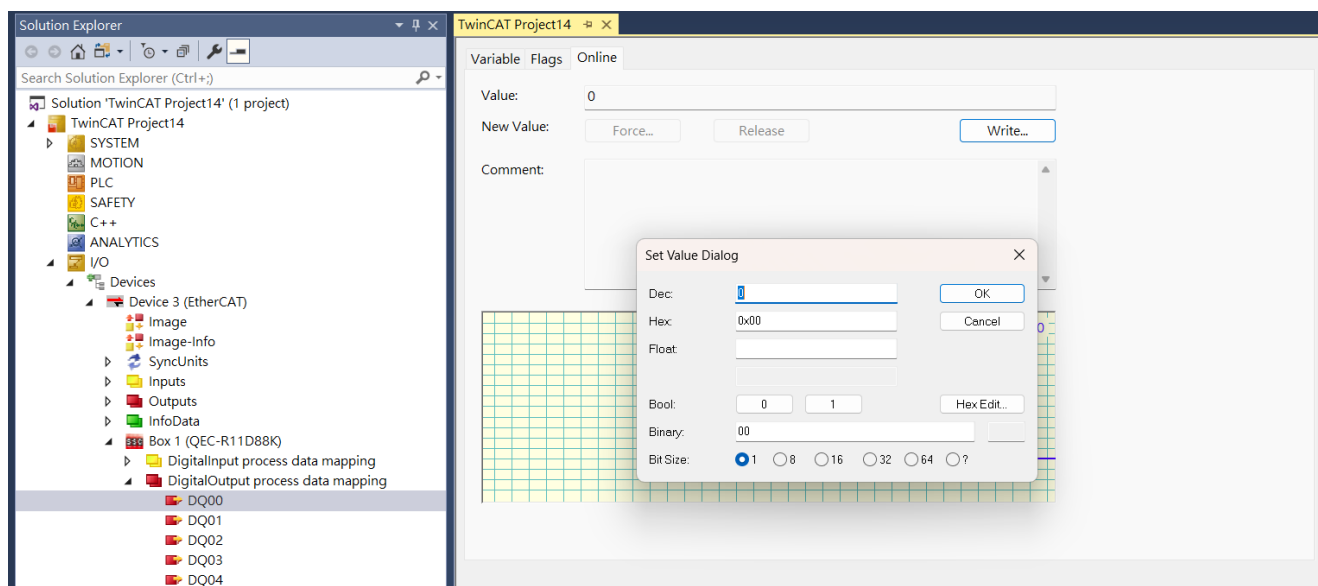

3. Then, the “DQ00” starts pull high (“Value” equals 1).

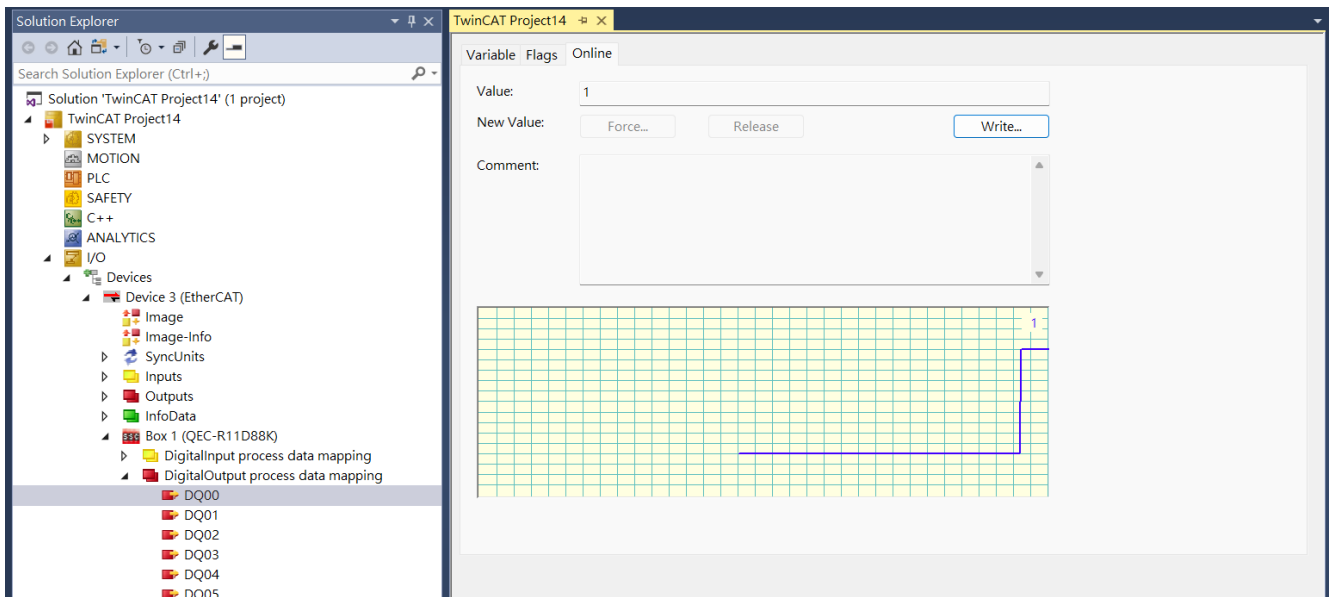

If you enter 0 to the Value, the “DQ00” starts pull low.

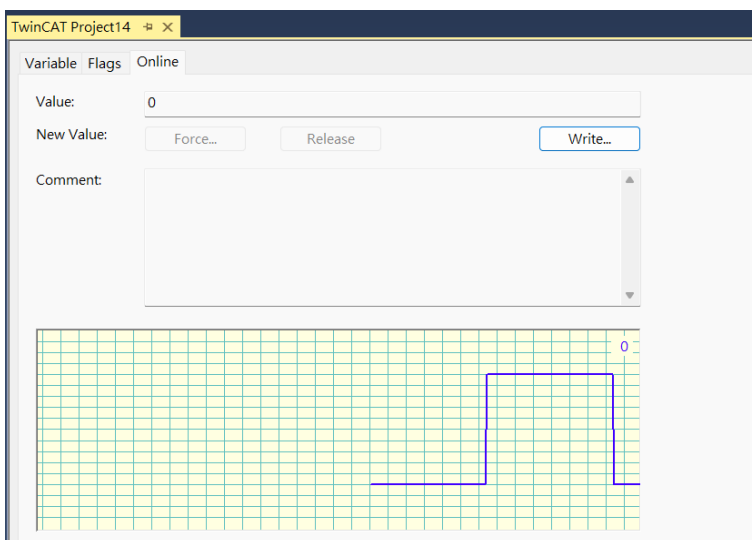

4.3.4.2 Read the Digital Input

Read the Digital Input.

1. Select the drop-down list of the **“Input mapping 0”**. Click the **“DI00”** and it’ll appear control dashboard in the right windows.

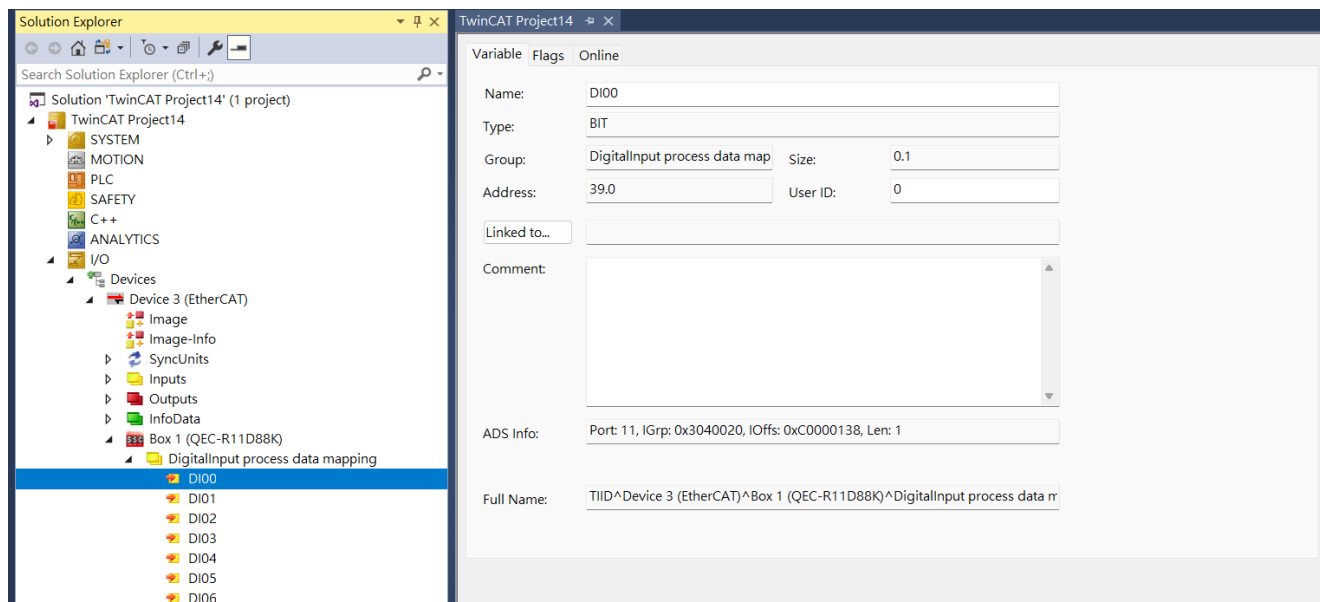

2. Click the **“Online”** tab, and you can see the Value from the DI00 channel if its value changed.

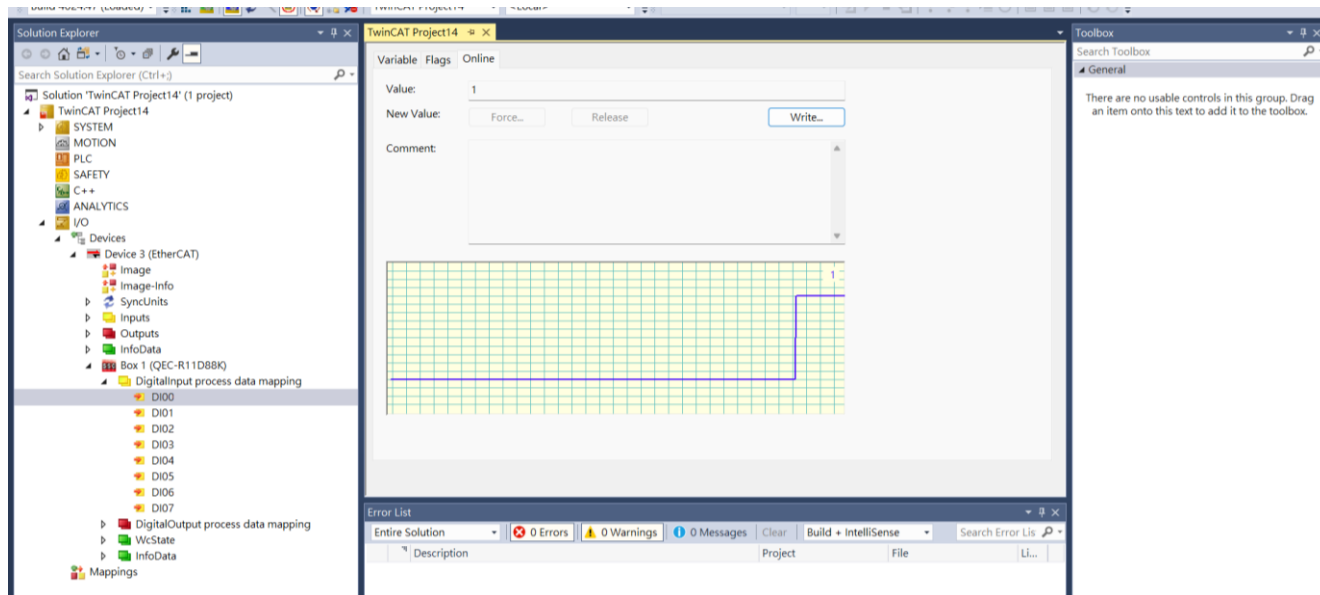



Ch. 5

SubDevice Information

5.1 ESI (EtherCAT SubDevice Information) file

The ESI files contain information unique to the EtherCAT SubDevice Terminals in XML format. You can load an ESI file into the Support Software to easily allocate SubDevice Terminal process data and other settings. The ESI files for QEC EtherCAT SubDevice are already installed in the Support Software.

*** Note: Ensuring Up-to-date Installation of the XML Device Description File (ESI)**

To ensure smooth functioning, it is important to install the latest version of the XML device description file in the EtherCAT Master software. The latest version of the XML device description file can be downloaded from the QEC website.

<https://www.qec.tw/>

5.2 Object Dictionary

The object dictionary defined here shall be used complementary with ETG.5001 and ETG.1000.

- Device Profile: 5001
- Modul Profile: 0
- Modular Device Profile
- Usage Notes:
 - The PDO mapping object and SyncManager assignment object doesn't need to be defined. In that case they are created automatically.
 - The following objects are fixed included in the SSC and shall not be defined in the file: 0x1000, 0x1001, 0x1008, 0x1009, 0x100a, 0x1010, 0x1011, 0x1018, 0x10F0, 0x10F1, 0x10F3, 0x1c00, 0x1c32, 0x1c33.
 - Entries less or equal one 8Bit shall not overlap byte borders.
 - Entries greater 8Bit shall always start at an exact word border.

*** Note:** All descriptions in the object dictionary are only for High-speed Digital Modules (QEC-RXXDT0H and QEC-RXX0TH)

5.2.1 Standard Objects (0x1000-0x1FFF)

Index 1000 Device type

Index	Name	Data type	Flags	Default
1000	Device type	UINT32	RO	0x00001389 (5001)

Index 1001 Error register

Index	Name	Data type	Flags	Default
1001	Error register	UINT8	RO	0x00 (0)

Index 1008 Device name

Index	Name	Data type	Flags	Default
1008	Device name	STRING	RO	Refer to following table.

Table 4-1: Device Name

Type	Device Name
Digital Input	QEC-R00DT0H
	QEC-R11DT0H
Digital Output	QEC-R00D0TH
	QEC-R11D0TH

Index 1009 Hardware version

Index	Name	Data type	Flags	Default
1009	Hardware version	STRING	RO	Depending by model.

Index 100A

Index	Name	Data type	Flags	Default
100A	Software version	STRING	RO	1.00

Index 1018 Identity

Index	Name	Data type	Flags	Default
1018:0	Identity	UINT8	RO	> 4 <
1018:01	Vendor ID	UINT32	RO	0x00000BC3 (3011)
1018:02	Product code	UINT32	RO	Refer to following table.
1018:03	Revision	UINT32	RO	Depending by model.
1018:04	Serial number	UINT32	RO	0x00000000 (0)

Table 4-2: Product code & Revision Number

Model Name	Product code
QEC-R11DT0H	0x0086d700
QEC-R00DT0H	0x0086d701
QEC-R11D0TH	0x0086d800
QEC-R00D0TH	0x0086d801

Index 10F1 Error Settings

Index	Name	Data type	Flags	Default
10F1:0	Error Settings	UINT8	RO	> 2 <
10F1:01	Local Error Reaction	UINT32	RW	0x00000001 (1)
10F1:02	Sync Error Counter Limit	UINT32	RW	0x0004 (4)

Index 10F8 Timestamp Object

Index	Name	Data type	Flags	Default
10F8	Timestamp Object	UINT8	RW P	-

Index 1600 Digital Output process data mapping

Index	Name	Data type	Flags	Default
1600:0	DigitalOutput process data mapping	UINT8	RO	Maximum of 32, by model.
1600:01	SubIndex 001	UINT32	RO	0x7000:01, 1
1600:02	SubIndex 002	UINT32	RO	0x7000:02, 1
1600:03	SubIndex 003	UINT32	RO	0x7000:03, 1
1600:04	SubIndex 004	UINT32	RO	0x7000:04, 1
1600:05	SubIndex 005	UINT32	RO	0x7000:05, 1
1600:06	SubIndex 006	UINT32	RO	0x7000:06, 1
1600:07	SubIndex 007	UINT32	RO	0x7000:07, 1
1600:08	SubIndex 008	UINT32	RO	0x7000:08, 1
1600:09	SubIndex 009	UINT32	RO	0x7000:09, 1
1600:0A	SubIndex 010	UINT32	RO	0x7000:0A, 1
1600:0B	SubIndex 011	UINT32	RO	0x7000:0B, 1
1600:0C	SubIndex 012	UINT32	RO	0x7000:0C, 1
1600:0D	SubIndex 013	UINT32	RO	0x7000:0D, 1
1600:0E	SubIndex 014	UINT32	RO	0x7000:0E, 1
1600:0F	SubIndex 015	UINT32	RO	0x7000:0F, 1
1600:10	SubIndex 016	UINT32	RO	0x7000:10, 1
1600:11	SubIndex 017	UINT32	RO	0x7000:11, 1
1600:12	SubIndex 018	UINT32	RO	0x7000:12, 1
1600:13	SubIndex 019	UINT32	RO	0x7000:13, 1
1600:14	SubIndex 020	UINT32	RO	0x7000:14, 1
1600:15	SubIndex 021	UINT32	RO	0x7000:15, 1
1600:16	SubIndex 022	UINT32	RO	0x7000:16, 1
1600:17	SubIndex 023	UINT32	RO	0x7000:17, 1
1600:18	SubIndex 024	UINT32	RO	0x7000:18, 1
1600:19	SubIndex 025	UINT32	RO	0x7000:19, 1
1600:1A	SubIndex 026	UINT32	RO	0x7000:1A, 1
1600:1B	SubIndex 027	UINT32	RO	0x7000:1B, 1
1600:1C	SubIndex 028	UINT32	RO	0x7000:1C, 1
1600:1D	SubIndex 029	UINT32	RO	0x7000:1D, 1
1600:1E	SubIndex 030	UINT32	RO	0x7000:1E, 1
1600:1F	SubIndex 031	UINT32	RO	0x7000:1F, 1
1600:20	SubIndex 032	UINT32	RO	0x7000:20, 1

Index 1A00 Digital Input process data mapping

Index	Name	Data type	Flags	Default
1A00:0	DigitalInput process data mapping	UINT8	RO	Maximum of 32, by model.
1A00:01	SubIndex 001	UINT32	RO	0x6000:01, 1
1A00:02	SubIndex 002	UINT32	RO	0x6000:02, 1
1A00:03	SubIndex 003	UINT32	RO	0x6000:03, 1
1A00:04	SubIndex 004	UINT32	RO	0x6000:04, 1
1A00:05	SubIndex 005	UINT32	RO	0x6000:05, 1
1A00:06	SubIndex 006	UINT32	RO	0x6000:06, 1
1A00:07	SubIndex 007	UINT32	RO	0x6000:07, 1
1A00:08	SubIndex 008	UINT32	RO	0x6000:08, 1
1A00:09	SubIndex 009	UINT32	RO	0x6000:09, 1
1A00:0A	SubIndex 010	UINT32	RO	0x6000:0A, 1
1A00:0B	SubIndex 011	UINT32	RO	0x6000:0B, 1
1A00:0C	SubIndex 012	UINT32	RO	0x6000:0C, 1
1A00:0D	SubIndex 013	UINT32	RO	0x6000:0D, 1
1A00:0E	SubIndex 014	UINT32	RO	0x6000:0E, 1
1A00:0F	SubIndex 015	UINT32	RO	0x6000:0F, 1
1A00:10	SubIndex 016	UINT32	RO	0x6000:10, 1
1A00:11	SubIndex 017	UINT32	RO	0x6000:11, 1
1A00:12	SubIndex 018	UINT32	RO	0x6000:12, 1
1A00:13	SubIndex 019	UINT32	RO	0x6000:13, 1
1A00:14	SubIndex 020	UINT32	RO	0x6000:14, 1
1A00:15	SubIndex 021	UINT32	RO	0x6000:15, 1
1A00:16	SubIndex 022	UINT32	RO	0x6000:16, 1
1A00:17	SubIndex 023	UINT32	RO	0x6000:17, 1
1A00:18	SubIndex 024	UINT32	RO	0x6000:18, 1
1A00:19	SubIndex 025	UINT32	RO	0x6000:19, 1
1A00:1A	SubIndex 026	UINT32	RO	0x6000:1A, 1
1A00:1B	SubIndex 027	UINT32	RO	0x6000:1B, 1
1A00:1C	SubIndex 028	UINT32	RO	0x6000:1C, 1
1A00:1D	SubIndex 029	UINT32	RO	0x6000:1D, 1
1A00:1E	SubIndex 030	UINT32	RO	0x6000:1E, 1
1A00:1F	SubIndex 031	UINT32	RO	0x6000:1F, 1
1A00:20	SubIndex 032	UINT32	RO	0x6000:20, 1

Index 1C00 Sync manager type

Index	Name	Data type	Flags	Default
1C00:0	Sync manager type	UINT8	R0	> 4 <
1C00:01	SubIndex 001	UINT8	RO	0x01 (1)
1C00:02	SubIndex 002	UINT8	RO	0x02 (2)
1C00:03	SubIndex 003	UINT8	RO	0x03 (3)
1C00:04	SubIndex 004	UINT8	RO	0x04 (4)

Index 1C12 SyncManager 2 assignment

Index	Name	Data type	Flags	Default
1C12:0	SyncManager 2 assignment	UINT8	R0	> 1 <
1C12:01	SubIndex 001	UINT16	RO	0x1600 (5632)

Index 1C13 SyncManager 3 assignment

Index	Name	Data type	Flags	Default
1C13:0	SyncManager 3 assignment	UINT8	R0	> 1 <
1C13:01	SubIndex 001	UINT16	RO	0x1A00 (6656)

Index 1C32 SM output parameter

Index	Name	Data type	Flags	Default
1C32:0	SM output parameter	UINT8	RO	> 32 <
1C32:01	Synchronization Type	UINT16	RW	0x0001 (1)
1C32:02	Cycle Time	UINT32	RO	0x00000000 (0)
1C32:04	Synchronization Types supported	UINT16	RO	0x401F (16415)
1C32:05	Minimum Cycle Time	UINT32	RO	0x000186A0 (100000)
1C32:06	Calc and Copy Time	UINT32	RO	0x00000000 (0)
1C32:08	Get Cycle Time	UINT16	RW	0x0000 (0)
1C32:09	Delay Time	UINT32	RO	0x00000000 (0)
1C32:0A	Sync0 Cycle Time	UINT32	RW	0x00000000 (0)
1C32:0B	SM-Event Missed	UINT16	RO	0x0000 (0)
1C32:0C	Cycle Time Too Small	UINT16	RO	0x010D (269)
1C32:0D	Shift Time Too Short Counter	UINT16	RO	0xCAD3 (51923)
1C32:20	Sync Error	BOOL	RO	TRUE

Index 1C33 SM input parameter

Index	Name	Data type	Flags	Default
1C33:0	SM input parameter	UINT8	RO	> 32 <
1C33:01	Synchronization Type	UINT16	RW	0x0001 (1)
1C33:02	Cycle Time	UINT32	RO	0x00000000 (0)
1C33:04	Synchronization Types supported	UINT16	RO	0x405F (16479)
1C33:05	Minimum Cycle Time	UINT32	RO	0x000186A0 (100000)
1C33:06	Calc and Copy Time	UINT32	RO	0x00000000 (0)
1C33:08	Get Cycle Time	UINT16	RW	0x0000 (0)
1C33:09	Delay Time	UINT32	RO	0x00000000 (0)
1C33:0A	Sync0 Cycle Time	UINT32	RW	0x00000000 (0)
1C33:0B	SM-Event Missed	UINT16	RO	0x0000 (0)
1C33:0C	Cycle Time Too Small	UINT16	RO	0x0709 (1801)
1C33:0D	Shift Time Too Short Counter	UINT16	RO	0x0000 (0)
1C33:20	Sync Error	BOOL	RO	TRUE

5.2.2 Manufacturer Objects (0x5000-0x5FFF)

Index 0x5xxn Manufacturer Objects

Index	Object Code	Data Type	Name	Default	Description
0x5000	VARIABLE	UINT16	SP_Voltage	0	Read SP Voltage
0x5001	VARIABLE	UINT16	SP_Current	0	Read SP Current
0x5002	VARIABLE	UINT16	PP_Voltage	0	Read PP Voltage
0x5003	VARIABLE	UINT16	PP_Current	0	Read PP Current
0x5004	VARIABLE	INT16	Temperature	0	Read Temperature
0x5005	VARIABLE	UINT8	BoxStatus	0	NormalOperation 0 ESC_3p3_Power_NG 3 DIQ_3p3_Power_NG 4 EXT_Xtal_Stop 5 EXT_Xtal_OverRang 6 PowerVoltageLowOrHigh 0x10 PowerVoltageTooLowOrTooOver 0x11
0x5006	RECORD	UINT8	OrderInformation	> 4 <	OrderInformation
0x5006:01		STRING(6)	customerID	000000	Customer ID
0x5006:02		STRING(8)	poNumber	00000000	Po Number
0x5006:03		STRING(11)	orderNumber	00000000000	Order Number
0x5006:04		STRING(4)	preDeliveryDate	0000	Pre-Delivery Date
0x5007	VARIABLE	UINT32	MTBF		Record machine operating time. (Counter will push 1 for the Device on/off and per hour)

5.2.3 Especial Objects (0x6000-0xFFFF)

Index 0x6nnx Input Data of the Module (0x6000 - 0x6FFF)

Digital input index data. (QEC-RXXDT0H)

Index	Object Code	Data Type	Name	Default	Description
0x6000	RECORD		DigitalInput	RO P	Digital Input (tx).
		BOOL	DI00		
		BOOL	DI01		
		BOOL	DI02		
		BOOL	DI03		
		BOOL	DI04		
		BOOL	DI05		
		BOOL	DI06		
		BOOL	DI07		
		BOOL	DI08		
		BOOL	DI09		
		BOOL	DI10		
		BOOL	DI11		
		BOOL	DI12		
		BOOL	DI13		
		BOOL	DI14		
		BOOL	DI15		
		BOOL	DI16		
		BOOL	DI17		
		BOOL	DI18		
		BOOL	DI19		
		BOOL	DI20		
		BOOL	DI21		
		BOOL	DI22		
		BOOL	DI23		
		BOOL	DI24		
		BOOL	DI25		
		BOOL	DI26		
		BOOL	DI27		
		BOOL	DI28		
		BOOL	DI29		
		BOOL	DI30		
		BOOL	DI31		

Index 0x7nnx Output Data of the Module (0x7000 - 0x7FFF)

Digital output index data. (QEC-RXXD0TH)

Index	Object Code	Data Type	Name	Default	Description
0x7000	RECORD		DigitalOutput	RO P	Digital Output (rx).
		BOOL	D000	0	
		BOOL	D001	0	
		BOOL	D002	0	
		BOOL	D003	0	
		BOOL	D004	0	
		BOOL	D005	0	
		BOOL	D006	0	
		BOOL	D007	0	
		BOOL	D008	0	
		BOOL	D009	0	
		BOOL	D010	0	
		BOOL	D011	0	
		BOOL	D012	0	
		BOOL	D013	0	
		BOOL	D014	0	
		BOOL	D015	0	
		BOOL	D016		
		BOOL	D017		
		BOOL	D018		
		BOOL	D019		
		BOOL	D020		
		BOOL	D021		
		BOOL	D022		
		BOOL	D023		
		BOOL	D024		
		BOOL	D025		
		BOOL	D026		
		BOOL	D027		
		BOOL	D028		
		BOOL	D029		
		BOOL	D030		
		BOOL	D031		

Warranty

This product is warranted to be in good working order for a period of one year from the date of purchase. Should this product fail to be in good working order at any time during this period, we will, at our option, replace or repair it at no additional charge except as set forth in the following terms. This warranty does not apply to products damaged by misuse, modifications, accident or disaster. Vendor assumes no liability for any damages, lost profits, lost savings or any other incidental or consequential damage resulting from the use, misuse of, originality to use this product. Vendor will not be liable for any claim made by any other related party. Return authorization must be obtained from the vendor before returned merchandise will be accepted. Authorization can be obtained by calling or faxing the vendor and requesting a Return Merchandise Authorization (RMA) number. Returned goods should always be accompanied by a clear problem description.

All Trademarks appearing in this manuscript are registered trademark of their respective owners. All Specifications are subject to change without notice.

©ICOP Technology Inc. 2026